



Austrian Institute of Construction Engineering
Schenkenstrasse 4 | T+43 1 533 65 50
1010 Vienna | Austria | F+43 1 533 64 23
www.oib.or.at | mail@oib.or.at



European Technical Assessment

ETA-12/0067
of 04.06.2018

General part

Technical Assessment Body issuing the European Technical Assessment

Österreichisches Institut für Bautechnik (OIB)
Austrian Institute of Construction Engineering

Trade name of the construction product

Sherpa XS, S, M, L, XL and XXL

Product family to which the construction product belongs

Three dimensional nailing plate (joist end connector for wood to wood connections and wood to concrete or steel connections)

Manufacturer

Vinzenz Harrer GmbH
Badl 31
8130 Frohnleiten
Austria

Manufacturing plant

Manufacturing plant 1

This European Technical Assessment contains

144 pages including 6 Annexes which form an integral part of this assessment.

This European Technical Assessment is issued in accordance with Regulation (EU) No 305/2011, on the basis of

Guideline for European Technical Approval ETAG 015 "Three-dimensional nailing plates", Edition November 2012, used as European Assessment Document

This European Technical Assessment replaces

European technical approval ETA-12/0067 with validity from 23.05.2013 to 22.05.2018.

Remarks

Translations of the European Technical Assessment in other languages shall fully correspond to the original issued document and should be identified as such.

Communication of this European Technical Assessment, including transmission by electronic means, shall be in full. However, partial reproduction may be made with the written consent of Austrian Institute of Construction Engineering. Any partial reproduction has to be identified as such.

Specific parts

1 Technical description of the product

1.1 General

This European Technical Assessment (ETA) ¹ applies to the beam hanger to be used in load-bearing timber to timber or timber to concrete or steel connections "**Sherpa**". **Sherpa** comprises two pieces following the tongue and groove principle. The overall thickness of **Sherpa** series XS, S, M, L, XL and XXL is shown in Table 1. Installation of the two pieces of the beam hanger into the timber is carried out with special screws with diameter according to Table 1 and to members made of concrete / steel with suitable anchors / screws. Optionally **Sherpa** series XS, S, M, L, XL and XXL can be provided with a lift lock.

Table 1: Overall thickness of Sherpa and diameter of screws for installation in wood

Sherpa series	Overall thickness	Diameter of screws
	mm	mm
XS	12	4.5
S	12	4.5
M	14	6.5
L	18	8
XL	20	8
XXL	20	8

Sherpa corresponds to the specifications given in the Annexes 1 to 3 and 5. The material characteristics, dimensions and tolerances of **Sherpa**, not indicated in these Annexes, are given in the technical file² of the European Technical Assessment.

1.2 Components

1.2.1 Beam hanger

Sherpa XS, S, M and L is produced of aluminium EN AW - 6082 according to EN 755-2³.

Sherpa XL and XXL is produced of aluminium EN AW - 5083 according to EN 755-2.

¹ The ETA-12/0067 was firstly issued in 2012 as European technical approval with validity from 15.06.2012, amended in 2013 with validity from 23.05.2013 and amended and converted in 2018 to the European Technical Assessment ETA-12/0067 of 04.06.2018.

² The technical file of the European Technical Assessment is deposited at Österreichisches Institut für Bautechnik and, in so far as is relevant to the tasks of the notified factory production control certification body involved in the assessment and verification of constancy of performance procedure, is handed over to the notified factory production control certification body.

³ Reference documents are listed in Annex 6.

The production series **Sherpa** XS, S, M, L, XL and XXL includes 39 different types of beam hangers for wood to wood connections:

→ XS 5, XS 10, XS 15, XS 20,

→ S 5, S 10, S 15, S 20,

→ M 15, M 20, M 25, M 30, M 40,

→ L 30, L 40, L 50, L 60, L 80, L100, L120,

→ XL 55, XL 70, XL 80, XL 100, XL 120, XL 140, XL 170, XL 190, XL 220, XL 250,

→ XXL 100, XXL 120, XXL 140, XXL 170, XXL 190, XXL 220, XXL 250, XXL 280 and XXL 300.

In addition 31 different types of beam hangers of **Sherpa** M, L, XL and XXL are produced for wood to concrete or steel connections:

→ M 15 CS, M 20 CS, M 25 CS, M 30 CS, M 40 CS,

→ L 30 CS, L 40 CS, L 50 CS, L 60 CS, L 80 CS, L100 CS, L120 CS,

→ XL 55 CS, XL 70 CS, XL 80 CS, XL 100 CS, XL 120 CS, XL 140 CS, XL 170 CS, XL 190 CS, XL 220 CS, XL 250 CS,

→ XXL 100 CS, XXL 120 CS, XXL 140 CS, XXL 170 CS, XXL 190 CS, XXL 220 CS, XXL 250 CS, XXL 280 CS and XXL 300 CS.

The beam hangers are also produced in type "DUO". Hereby, the tongue and groove geometry is placed side by side in one aluminium plate.

The beam hangers together with their most important dimensions are shown in Annex 2.

1.2.2 Screws

The screws for installation of the two beam hanger parts into the timber are described in Annex 1.

The screws are made of carbon steel.

1.2.3 Lift lock

Optionally **Sherpa** XS, S, M, L, XL and XXL can be provided with a lift lock. One hole is drilled into the upper piece of the beam hanger for **Sherpa** XS, S and M. Two holes are drilled into the upper piece of the beam hanger for **Sherpa** L, XL and XXL.

Thread rolling screws made of galvanized, hardened and tempered steel are screwed into the predrilled holes to joint the two pieces, see Annex 1.

2 Specification of the intended use(s) in accordance with the applicable European Assessment Document

2.1 Intended use

The beam hangers are intended to be used in load bearing connections of timber structures as end grain to side grain, end grain to end grain or side grain to side grain connections, e.g. between beams as well as connections between timber and a concrete structure or a steel member.

The beam hangers are used for connections in load bearing timber structures between the following wood-based members:

- Solid timber of softwood of strength class C24 or better according to EN 338 and EN 14081-1,
- Glued laminated timber and glued solid timber of softwood of strength class GL24c or better according to EN 14080 or glued laminated timber of hardwood according to European Technical Assessments or national provisions that apply on the installation site,
- Laminated veneer lumber LVL according to EN 14374 or according to European Technical Assessments or national provisions that apply on the installation site,

- Cross laminated timber according to European Technical Assessments or national provisions that apply on the installation site,
- Strand lumber (e.g. Laminated Strand Lumber - Intrallam, Parallelel Strand Lumber - Parallam) according to European Technical Assessments or national provisions that apply on the installation site.

The typical installation of the beam hangers is shown in Annex 3.

The beam hangers shall be subjected to static and quasi static actions only.

The beam hangers are intended to be used in service classes 1 and 2 according to EN 1995-1-1.

2.2 General assumptions

Sherpa is manufactured in accordance with the provisions of the European Technical Assessment using the manufacturing process as identified in the inspection of the manufacturing plant by Österreichisches Institut für Bautechnik and laid down in the technical file.

The manufacturer shall ensure that the requirements in accordance with the Clauses 1, 2 and 3 as well as with the Annexes of the European Technical Assessment are made known to those who are concerned with design and execution of the works.

Design

The European Technical Assessment only applies to the manufacture and use of the beam hangers. Verification of stability of the works including application of loads on the product is not subject to the European Technical Assessment.

The following conditions shall be observed:

- Design of connections with beam hangers is carried out under the responsibility of an engineer experienced in timber structures.
- Design of the works shall account for the protection of the connection to maintain service class 1 or 2 according to EN 1995-1-1.
- The beam hangers are installed correctly.
- For the forces R_2 and R_{45} according to Annex 4 it shall be checked in accordance with EN 1995-1-1 that splitting will not occur.
- Taking into consideration whether or not a lift-lock has been applied.

Design of connections with beam hangers may be according to EN 1995-1-1 taking into account the Annexes of the European Technical Assessment. Standards and regulations in force at the place of use shall be considered.

Design of connections with beam hangers in wood to concrete or steel connections in accordance with Eurocode 2, 3, 5 or 9 and Annex 5.

Packaging, transport, storage, maintenance, replacement and repair

Concerning product packaging, transport, storage, maintenance, replacement and repair it is the responsibility of the manufacturer to undertake the appropriate measures and to advise his clients on the transport, storage, maintenance, replacement and repair of the product as he considers necessary.

Installation

It is assumed that the product will be installed according to the manufacturer's instructions or (in absence of such instructions) according to the usual practice of the building professionals.

The beam hangers shall be screwed as specified in Annex 1 and Annex 3.

The inclined screws installed into glued laminated timber of hardwood or laminated veneer lumber of hardwood may be installed without predrilling whereas the moment screws shall be predrilled.

The structural members which are connected with the beam hangers shall be

- as detailed in Annex 3, either restrained against rotation, or for the case that main beam or column cannot be prevented from rotation in a satisfying way or are arranged rotatable according to plan, the characteristic load bearing capacity shall be attenuated according to Annex 5;
- wood-based members according to clause 2.1;
- free from wane under the beam hanger;
- with plane surfaces against the beam hangers;
- without virtually gap between the timber members;
- with minimum spacing and edge distances in accordance with EN 1995-1-1.

The rules for wood to wood connections are also applicable for the connection between wood to concrete or steel.

In addition, the following conditions shall be observed:

- The beam hanger shall be close in contact with the concrete or steel over the whole face.
- The fastener shall have a diameter not less than the hole diameter minus 2 mm.

2.3 Working life/Durability

The provisions made in the European Technical Assessment (ETA) are based on an assumed intended working life of **Sherpa** of 50 years, when installed in the works, provided that the product is subject to appropriate installation, use and maintenance (see Clause 2.2). These provisions are based upon the current state of the art and the available knowledge and experience⁴.

The indications given as to the working life of the construction product cannot be interpreted as a guarantee neither given by the product manufacturer or his representative nor by EOTA nor by the Technical Assessment Body, but are regarded only as a means for choosing the appropriate products in relation to the expected economically reasonable working life of the works.

⁴ The real working life of a product incorporated in a specific works depends on the environmental conditions to which that works is subject, as well as on the particular conditions of the design, execution, use and maintenance of that works. Therefore, it cannot be excluded that in certain cases the real working life of the product can also be shorter than the assumed working life.

3 Performance of the product and reference to the methods used for its assessment

3.1 Essential characteristics of the product

Table 2: Essential characteristics of the product and product performance

No	Essential characteristic	Product performance
Basic requirement for construction works 1: Mechanical resistance and stability ¹⁾		
1	Characteristic load bearing capacity	3.1.1
2	Stiffness	3.1.2
3	Ductility in cyclic testing	No performance assessed.
Basic Requirement 2: Safety in case of fire		
4	Reaction to fire	3.1.3
5	Resistance to fire	3.1.4
Basic requirement for construction works 3: Hygiene, health and the environment		
6	Content, emission and/or release of dangerous substances	3.1.5
Basic requirement for construction works 4: Safety and accessibility in use		
7	Same as basic requirement for construction works 1	
Basic requirement for construction works 5: Protection against noise		
–	Not relevant. No characteristic assessed.	
Basic requirement for construction works 6: Energy economy and heat retention		
–	Not relevant. No characteristic assessed.	
Basic requirement for construction works 7: Sustainable use of natural resources		
–	No characteristic assessed.	
General aspects		
8	Resistance to corrosion and deterioration	3.1.6
9	Dimensional stability	3.1.7
¹⁾ These characteristics also relate to basic requirement for construction works 4.		

3.1.1 Characteristic load bearing capacity

The characteristic load bearing capacities of the beam hangers are determined by calculation assisted by testing. The beam hangers are installed with a defined number of screws with respective nominal diameter as specified in Annex 1. Kinematic restraints are defined in Annex 4.

The values of the characteristic load bearing capacities for the loading directions R_1 , R_2 , R_3 , R_{45} and R_{tor} , as defined in Annex 4, are given in Annex 5.

If the beam hangers are connected to structural members made of concrete or steel, anchors or suitable screws are used. The same load bearing capacities shall be used as for timber-to-timber connections given in Annex 5, provided the anchors / screws are designed to exceed the load bearing capacities of the beam hanger to timber connections. In addition, for loading in direction of insertion, the specifications for connections between wooden members and concrete and steel members given in Annex 5 shall be considered.

3.1.2 Stiffness

The stiffness of the beam hangers was determined by calculation assisted by testing. The beam hangers are installed with a defined number of screws with respective nominal diameter as specified in Annex 1. The stiffness values are given in Annex 5.

3.1.3 Reaction to fire

The beam hangers are made from aluminium and the screws are made from carbon steel, both classified as Euroclass A1 in accordance with Commission Decision 96/603/EC as amended.

3.1.4 Resistance to fire

Classification R30 for beam hanger type M, L, XL and XXL in solid wood and glued laminated timber

- milled into the wood-based members with a joint width ≤ 5 mm or
- with a joint provided with a min. 20 mm wide penetration seal, type Intumex LSK 2.5 or SHERPA Fire Stop according to ETA-13/0286,
- and increase of the minimum cross section according to Table 3,
- valid for a conversion factor $\eta = 0.44$ according to EN 1995-1-2.

Table 3: Increase of the minimum cross section for classification R30

Sherpa series	Increase of edge distance on all sides exposed to fire $\Delta a_1 = \Delta a_3$	Increase of edge distance	
		Each side Δa_1	Bottom side Δa_3
	mm	mm	mm
M	+20	+15	+30
L	+15	+12.5	+17.5
XL	+12.5	+10	+20
XXL			

Classification R60 for beam hanger type M, L, XL and XXL in solid wood and glued laminated timber

- milled into the wood-based members with a joint width ≤ 5 mm or
- with a joint provided with a min. 40 mm (optional 2 x 20mm) wide penetration seal, type Intumex LSK 2.5 or SHERPA Fire Stop according to ETA-13/0286,
- and increase of the minimum cross section according to Table 4,
- valid for a conversion factor $\eta = 0.44$ according to EN 1995-1-2.

Table 4: Increase of the minimum cross section for classification R60

Sherpa series	Increase of edge distance on all sides exposed to fire $\Delta a_1 = \Delta a_3$	Increase of edge distance	
		Each side Δa_1	Bottom side Δa_3
	mm	mm	mm
M	+45	+50	+40
L	+40	+40	+40
XL			+30
XXL			+35

3.1.5 Content, emission and/or release of dangerous substances

The release of dangerous substances is determined according to ETAG 015. No dangerous substances is the performance of the product in this respect.

NOTE In addition to the specific clauses relating to dangerous substances contained in the European Technical Assessment, there may be other requirements applicable to the products falling within its scope (e.g. transposed European legislation and national laws, regulations and administrative provisions). In order to meet the provisions of the Construction Products Regulation, these requirements need also to be complied with, when and where they apply.

3.1.6 Resistance to corrosion and deterioration

The product is intended to be used in service classes 1 and 2 according to EN 1995-1-1. The product and each member of the connection should at least be suitable for service classes 1 and 2, but not for service class 1 only.

In accordance with ETAG 015 and EN 1995-1-1 the beam hangers of **Sherpa** series XS, S, M and L are made of aluminium EN AW - 6082 and the beam hangers of **Sherpa** series XL and XXL are made of aluminium EN AW - 5083 according to EN 755-2. The screws for installation are made of carbon steel and galvanised. For the lift lock thread rolling screws made of hardened and tempered steel are used.

3.1.7 Dimensional stability

The effects of dimensional changes on the wood or wood-based members being jointed due to varying moisture content was considered by the determination of the strength and the stiffness of the joints. Moisture content during service shall not change to such an extent that adverse deformation will occur. The conditions of Clause 2.2 shall be observed.

3.2 Assessment methods

3.2.1 General

The assessment of the essential characteristics in Clause 3.1 of **Sherpa** for the intended use, and in relation to the requirements for mechanical resistance and stability, for safety in case of fire, for hygiene, health and the environment and for safety and accessibility in use in the sense of the basic requirements for construction works № 1, 2, 3 and 4 of Regulation (EU) № 305/2011 has been made in accordance with Guideline for European Technical Approval ETAG № 015 "Three-dimensional nailing plates", edition November 2012, used as European Assessment Document.

3.2.2 Identification

The European Technical Assessment for **Sherpa** is issued on the basis of agreed data that identify the assessed product. Changes to materials, to composition, to characteristics of the product, or to the production process could result in these deposited data being incorrect. Österreichisches Institut für Bautechnik should be notified before the changes are implemented, as an amendment of the European Technical Assessment is possibly necessary.

4 Assessment and verification of constancy of performance (thereafter AVCP) system applied, with reference to its legal base

4.1 System of assessment and verification of constancy of performance

According to Commission Decision 97/638/EC the system of assessment and verification of constancy of performance to be applied to **Sherpa** is System 2+. System 2+ is detailed in Commission Delegated Regulation (EU) № 568/2014 of 18 February 2014, Annex, 1.3, and provides for the following items

(a) The manufacturer shall carry out:

- (i) an assessment of the performance of the construction product carried out on the basis of testing (including sampling), calculation, tabulated values or descriptive documentation of that product;
- (ii) factory production control;
- (iii) testing of samples taken at the manufacturing plant by the manufacturer in accordance with a prescribed test plan⁵.

(b) The notified factory production control certification body shall decide on the issuing, restriction, suspension or withdrawal of the certificate of conformity of the factory production control on the basis of the outcome of the following assessments and verifications carried out by that body:

- (i) initial inspection of the manufacturing plant and of factory production control;
- (ii) continuing surveillance, assessment and evaluation of factory production control.

4.2 AVCP for construction products for which a European Technical Assessment has been issued

Manufacturers undertaking tasks under Systems 2+ shall consider the European Technical Assessment issued for the construction product in question as the assessment of the performance of that product. Manufacturers shall therefore not undertake the tasks referred to in point 4.1 (a)(i).

5 Technical details necessary for the implementation of the AVCP system, as provided for in the applicable European Assessment Document

5.1 Tasks for the manufacturer

5.1.1 Factory production control

In the manufacturing plant the manufacturer shall establish and continuously maintain a factory production control. All procedures and specification adopted by the manufacturer shall be documented in a systematic manner. The factory production control shall ensure the constancy of performances of the product with regard to the essential characteristics.

The manufacturer shall only use raw materials supplied with the relevant inspection documents as laid down in the control plan. The incoming raw materials shall be subject to controls by the manufacturer before acceptance. Check of incoming materials shall include control of inspection documents presented by the manufacturer of the raw materials.

The frequencies of controls and tests conducted during manufacturing and on the assembled product are defined by taking account of the manufacturing process of the product and are laid down in the control plan.

⁵ The prescribed test plan has been deposited with Österreichisches Institut für Bautechnik and is handed over only to the notified factory production control certification body involved in the procedure for the assessment and verification of constancy of performance. The prescribed test plan is also referred to as control plan.

The results of factory production control are recorded and evaluated. The records include at least the following data:

- Designation of the product, basic materials and components
- Type of control or test
- Date of manufacture of the product and date of testing of the product or basic materials or components
- Results of controls and tests and, if appropriate, comparison with requirements
- Name and signature of person responsible for factory production control

The records shall be presented to the notified factory production control certification body involved in continuous surveillance. On request the records shall be presented to Österreichisches Institut für Bautechnik.

5.1.2 Declaration of performance

The manufacturer is responsible for preparing the declaration of performance. When all the criteria of the assessment and verification of constancy of performance are met, including the certificate of conformity of the factory production control issued by the notified factory production control certification body, the manufacturer shall draw up a declaration of performance.

5.2 Tasks for the notified factory production control certification body

5.2.1 Initial inspection of the manufacturing plant and of factory production control

The notified factory production control certification body shall verify the ability of the manufacturer for a continuous and orderly manufacturing of **Sherpa** according to the European Technical Assessment. In particular the following items shall be appropriately considered.

- Personnel and equipment
- The suitability of the factory production control established by the manufacturer
- Full implementation of the control plan

5.2.2 Continuous surveillance, assessment and evaluation of factory production control

The notified factory production control certification body shall visit the factory at least once a year for routine inspection. In particular the following items shall be appropriately considered.

- The manufacturing process including personnel and equipment
- The factory production control
- The implementation of the control plan

The results of continuous surveillance shall be made available on demand by the notified factory production control certification body to Österreichisches Institut für Bautechnik. When the provisions of the European Technical Assessment and the control plan are no longer fulfilled, the certificate of conformity of the factory production control shall be withdrawn.

Issued in Vienna on 04.06.2018
by Österreichisches Institut für Bautechnik

The original document is signed by:

Rainer Mikulits
Managing Director

Type	Number of Sherpa special-screws		Nominal diameter of screws	Nominal Length of screws		Tensile strength of screws
	side grain (moment/inclined)	end grain (moment/inclined)		side grain	end grain	
-	-	-	mm	mm	mm	N/mm ²
M 15	7 (4/3)	9 (5/4)	6.5	65/85/105	65/85/105	≥ 600
M 20	9 (4/5)	11 (5/6)				
M 25	10 (4/6)	13 (5/8)				
M 30	11 (4/7)	15 (5/10)				
M 40	13 (4/9)	17 (5/12)				

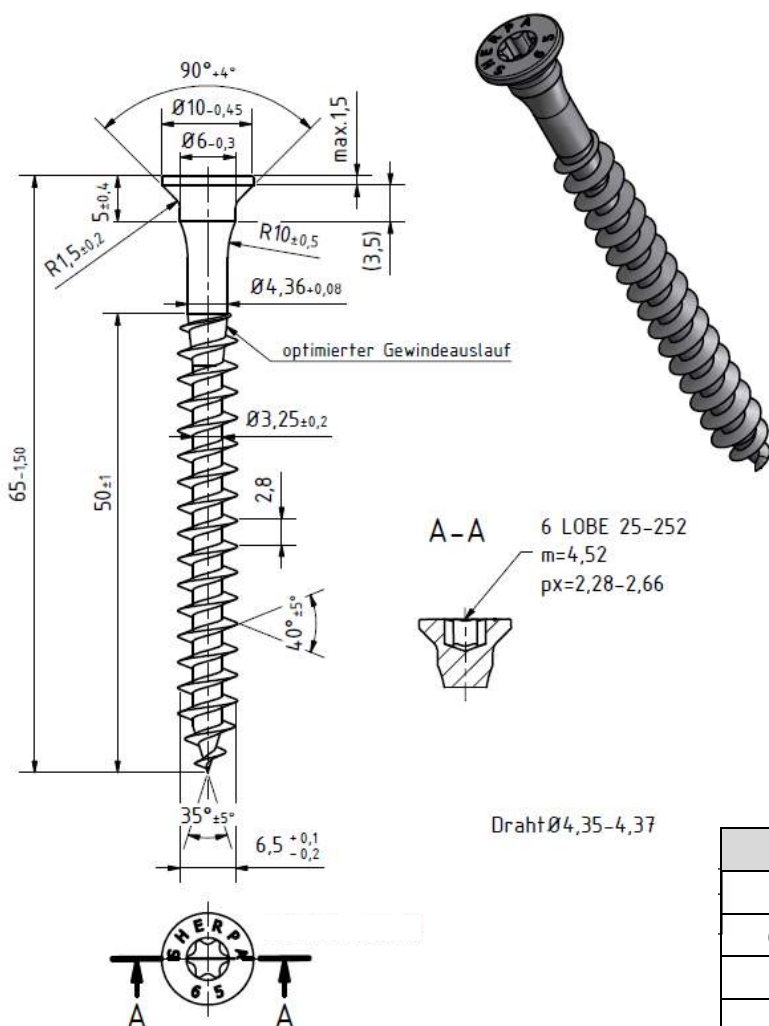

Dimensions	mm
Head diameter d_k	10
Outer thread diameter d_1	6.5
Inner thread diameter d_2	3.25
Flange diameter d_3	6
Length L	65/85/105
Pitch P	2.8

Sherpa –M	Annex 1 of European Technical Assessment ETA-12/0067 of 04.06.2018
Fastener specification – special screws	

Type	Number of Sherpa special-screws		Nominal diameter of screws	Nominal Length of screws		Tensile strength of screws
	side grain (moment/inclined)	end grain (moment/inclined)		side grain	end grain	
-	-	-	mm	mm	mm	N/mm ²
L 30	6 (2/4)	9 (5/4)	8	100/120/140	100/120/140	≥ 600
L 40	7 (2/5)	11 (5/6)				
L 50	8 (2/6)	13 (5/8)				
L 60	10 (2/8)	15 (5/10)				
L 80	12 (2/10)	17 (5/12)				
L 100	14 (2/12)	19 (5/14)				
L 120	16 (2/14)	21 (5/16)				

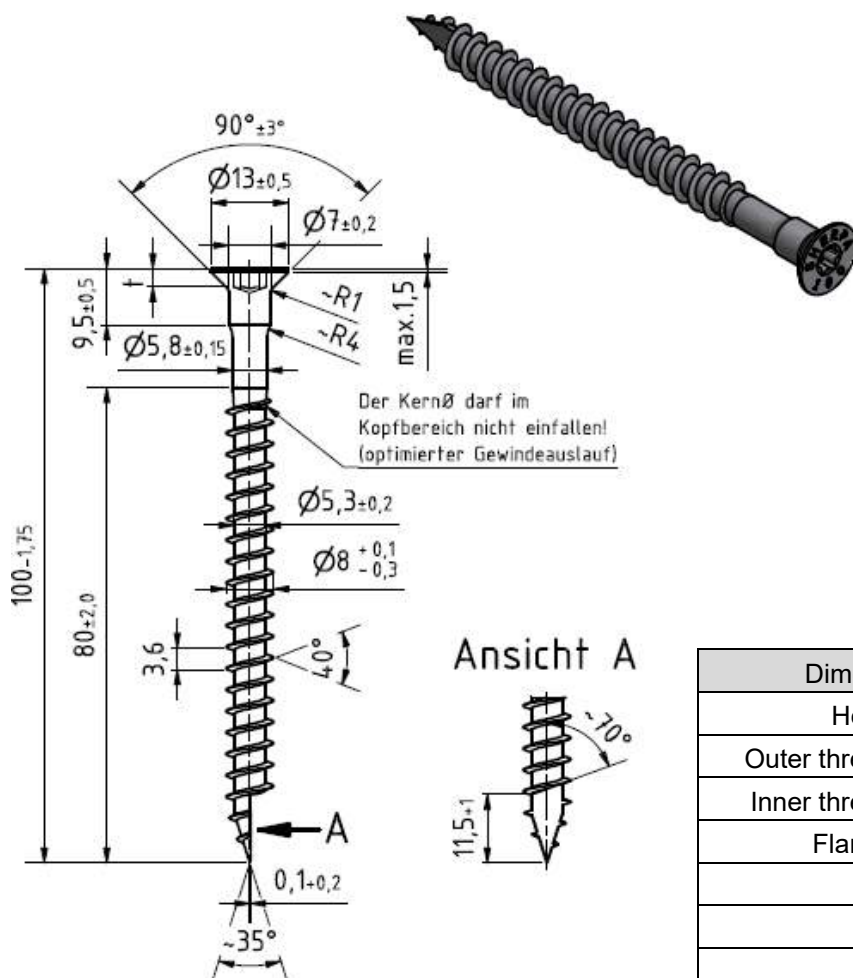

Dimensions	mm
Head diameter d_k	13
Outer thread diameter d_1	8
Inner thread diameter d_2	5.3
Flange diameter d_3	7
Length L	100/120/140
Pitch P	3.6
Milling length A	11.5
Center distance B	0.1

Sherpa –L

Fastener specification – special screws

Annex 1

of European Technical Assessment
 ETA-12/0067 of 04.06.2018

electronic copy electronic copy electronic copy electronic copy electronic copy electronic copy electronic copy electronic copy electronic copy electronic copy

Type	Number of Sherpa special-screws		Nominal diameter of screws	Nominal Length of screws		Tensile strength of screws
	side grain (moment/inclined)	end grain (moment/inclined)		side grain	end grain	
-	-	-	mm	mm	mm	N/mm ²
XL 55	8 (4/4)	10 (6/4)	8	100 to 200	100 to 200	≥ 600
XL 70	9 (4/5)	12 (6/6)				
XL 80	10 (4/6)	14 (6/8)				
XL 100	11 (4/7)	14 (6/8)				
XL 120	13 (4/9)	16 (6/10)				
XL 140	14 (4/10)	18 (6/12)				
XL 170	16 (4/12)	20 (6/14)				
XL 190	18 (4/14)	22 (6/16)				
XL 220	20 (4/16)	24 (6/18)				
XL 250	22 (4/18)	26 (6/20)				
XXL 100	10 (4/6)	12 (6/6)				
XXL 120	12 (4/8)	15 (6/9)				
XXL 140	14 (4/10)	18 (6/12)				
XXL 170	16 (4/12)	21 (6/15)				
XXL 190	18 (4/14)	24 (6/18)				
XXL 220	20 (4/16)	27 (6/21)				
XXL 250	22 (4/18)	30 (6/24)				
XXL 280	24 (4/20)	30 (6/24)				
XXL 300	26 (4/22)	33 (6/27)				

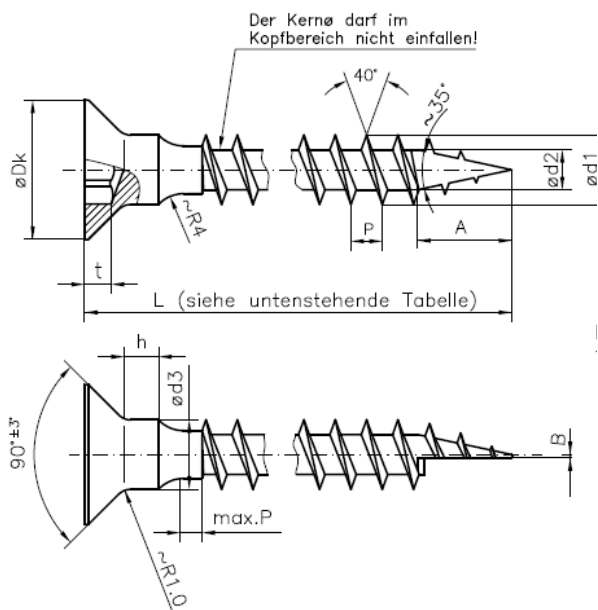

Dimensions	mm
Head diameter d_k	15.0
Outer thread diameter d_1	8.0
Inner thread diameter d_2	5.3
Flange diameter d_3	7.8
Length L	100 to 200
Pitch P	3.6
Milling length A	11
Center distance B	0.1

Sherpa – XL and XXL	Annex 1 of European Technical Assessment ETA-12/0067 of 04.06.2018
Fastener specification – special screws	

electronic copy electronic copy electronic copy electronic copy electronic copy electronic copy electronic copy electronic copy electronic copy electronic copy

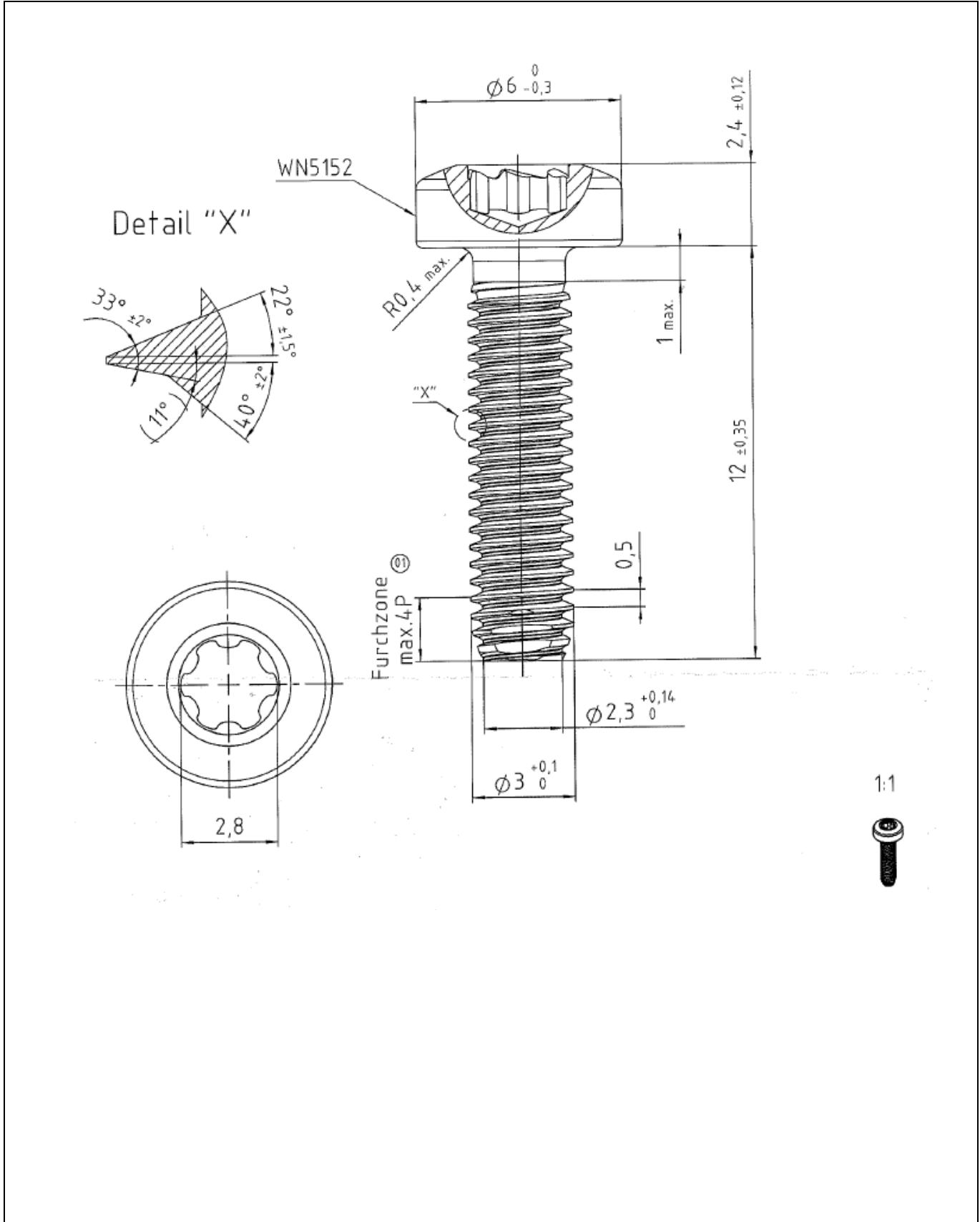

Sherpa – XS	Annex 1 of European Technical Assessment ETA-12/0067 of 04.06.2018
Fastener specification – Lift lock	

electronic copy electronic copy electronic copy electronic copy electronic copy electronic copy electronic copy electronic copy electronic copy electronic copy

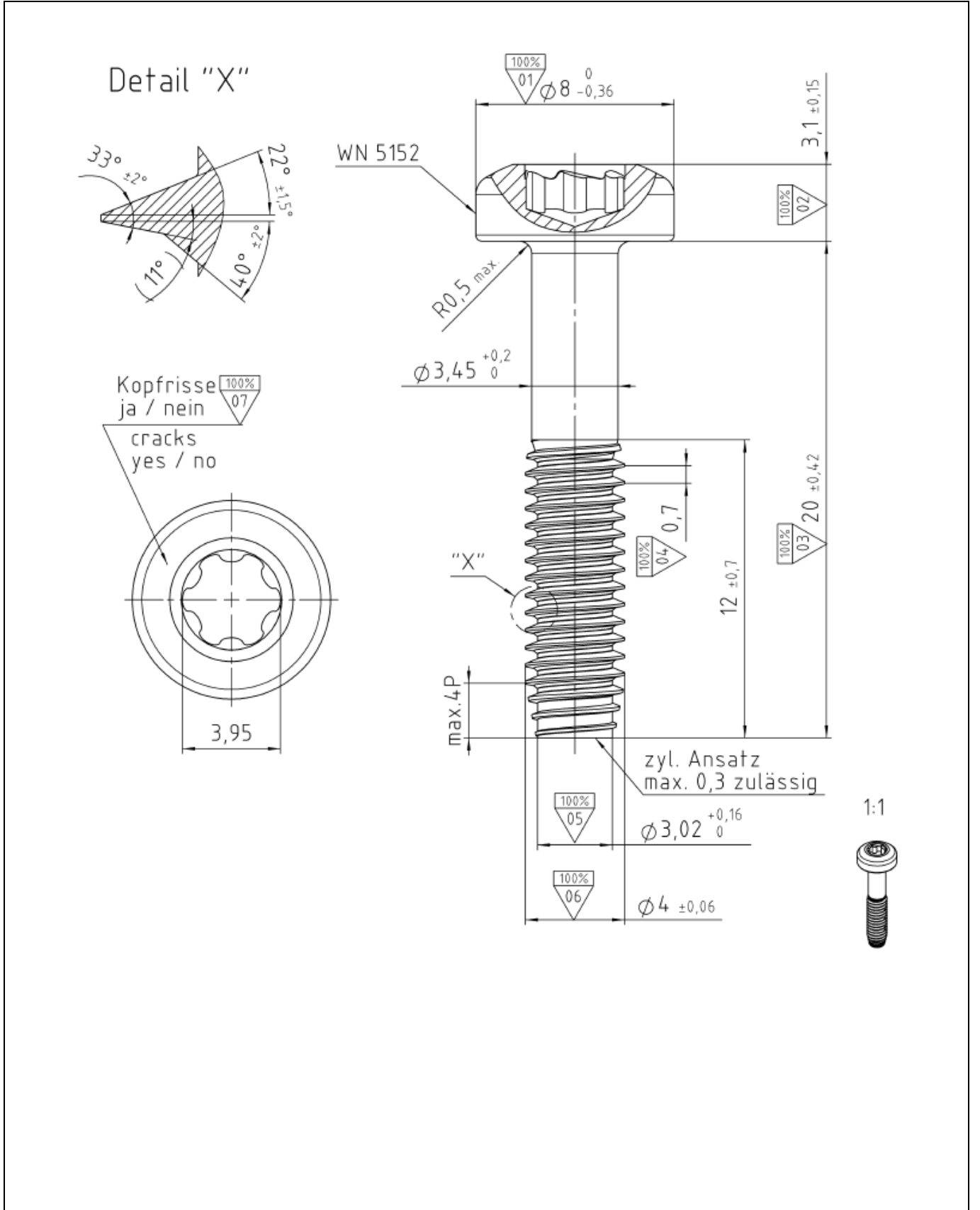

Sherpa – M	Annex 1 of European Technical Assessment ETA-12/0067 of 04.06.2018
Fastener specification – Lift lock	

electronic copy electronic copy electronic copy electronic copy electronic copy electronic copy electronic copy electronic copy electronic copy electronic copy

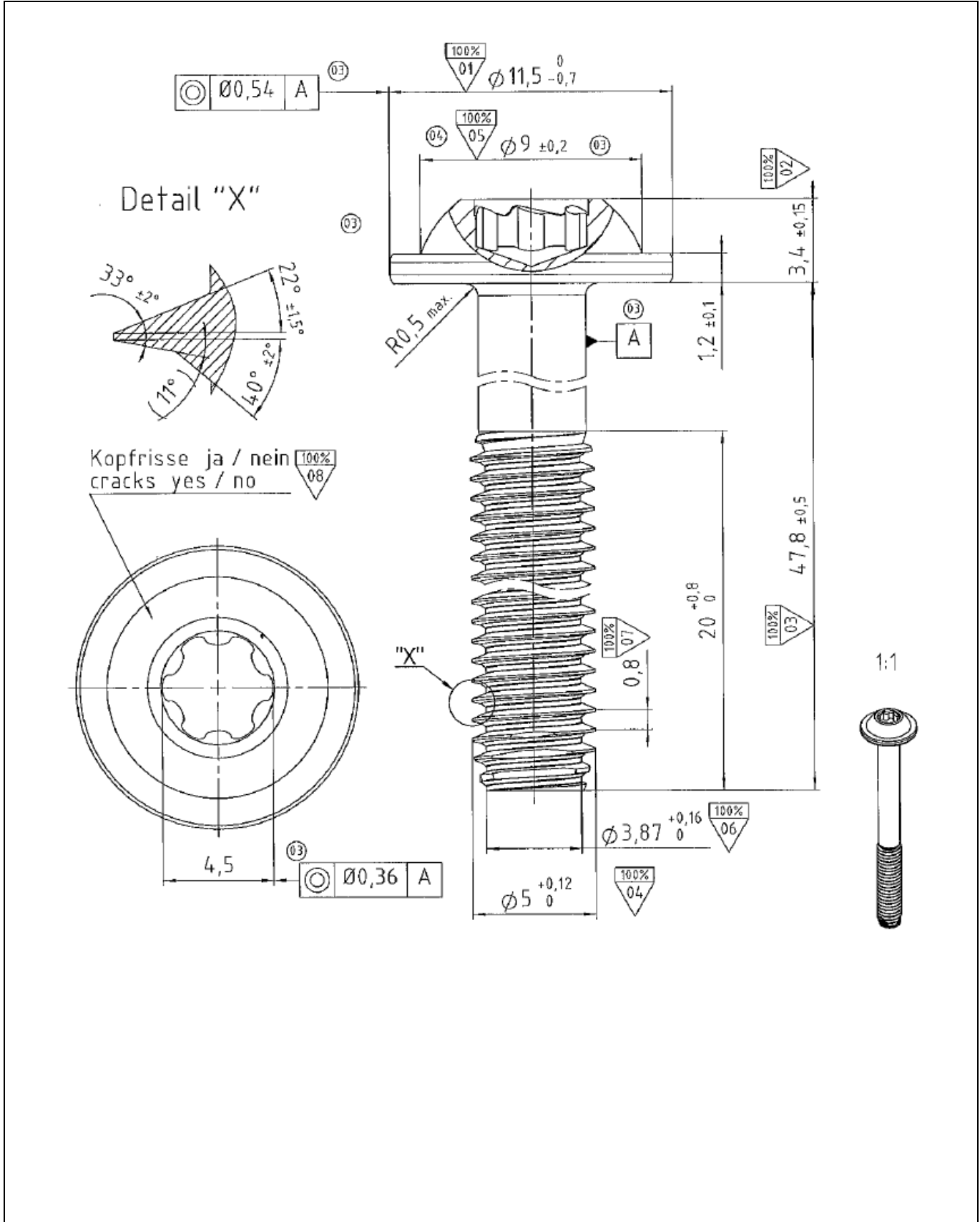

Sherpa – L	Annex 1 of European Technical Assessment ETA-12/0067 of 04.06.2018
Fastener specification – Lift lock	

electronic copy electronic copy electronic copy electronic copy electronic copy electronic copy electronic copy electronic copy electronic copy electronic copy

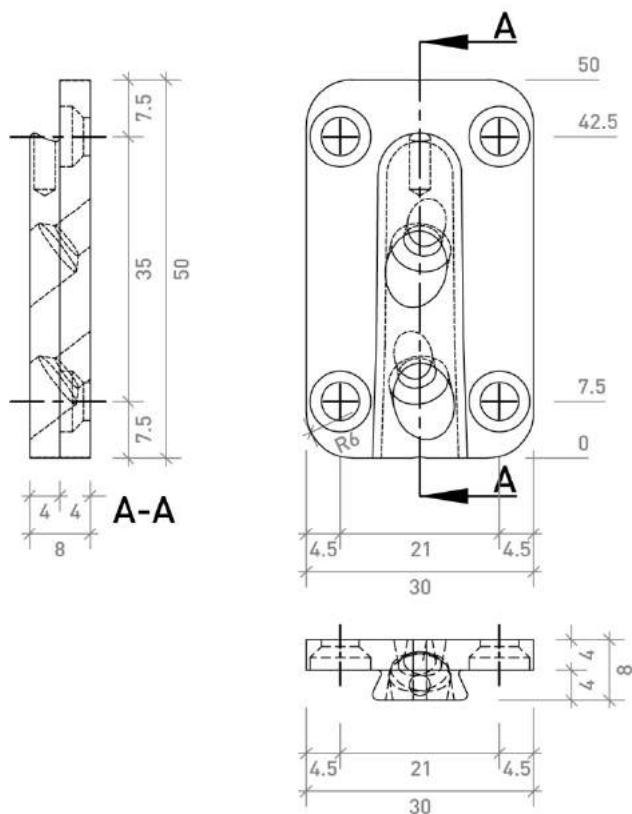

Dimensions in mm

Sherpa – XS	Annex 2 of European Technical Assessment ETA-12/0067 of 04.06.2018
Product details definitions: <u>Type XS 5 12/30/50</u> Mounting: <u>main beam or column</u>	

electronic copy electronic copy electronic copy electronic copy electronic copy electronic copy electronic copy electronic copy electronic copy electronic copy

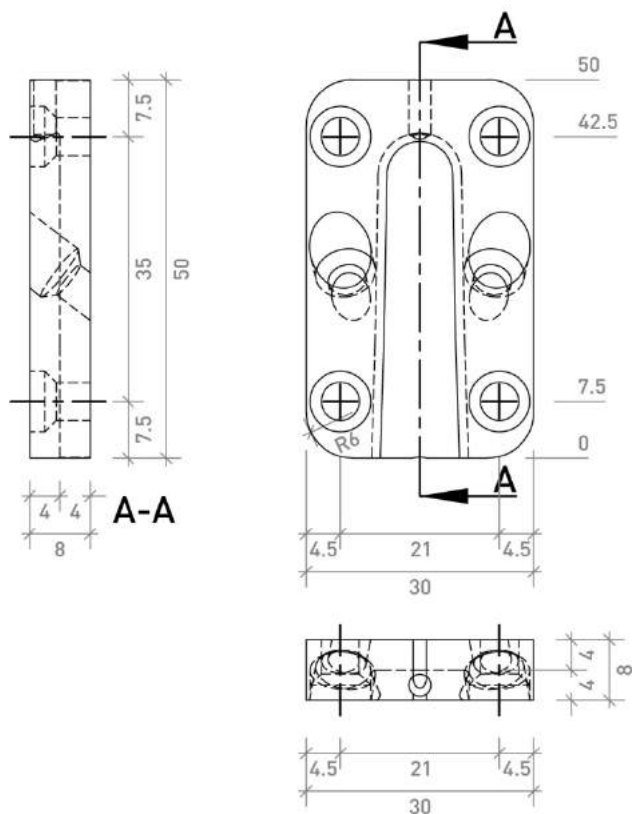

Dimensions in mm

Sherpa – XS

Product details definitions: Type XS 5 12/30/50
 Mounting: secondary beam

Annex 2

of European Technical Assessment
 ETA-12/0067 of 04.06.2018

electronic copy electronic copy electronic copy electronic copy electronic copy electronic copy electronic copy electronic copy electronic copy electronic copy

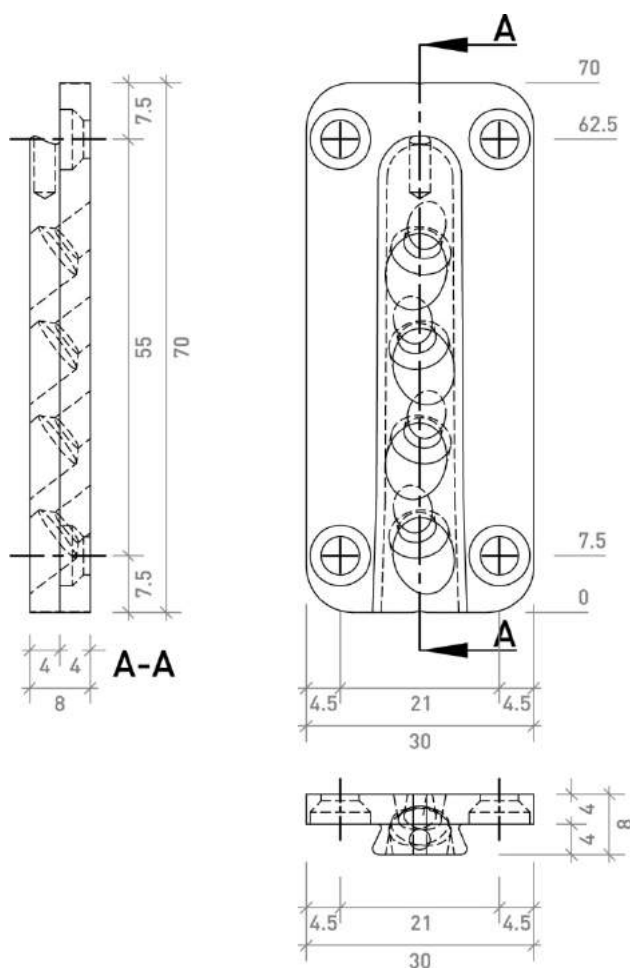

Dimensions in mm

Sherpa – XS	Annex 2 of European Technical Assessment ETA-12/0067 of 04.06.2018
Product details definitions: <u>Type XS 10 12/30/70</u> Mounting: <u>main beam or column</u>	

electronic copy electronic copy electronic copy electronic copy electronic copy electronic copy electronic copy electronic copy electronic copy electronic copy

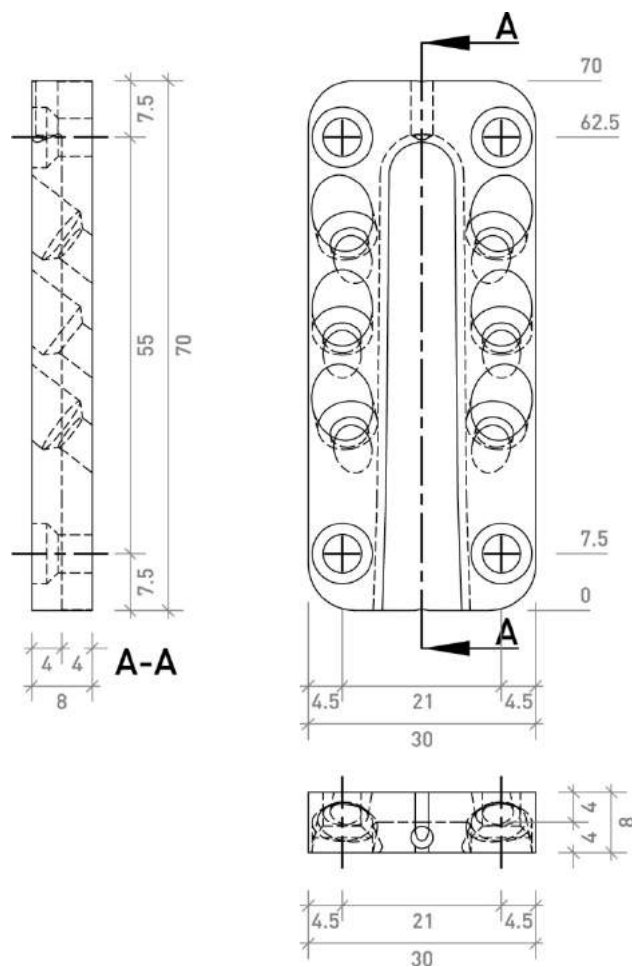

Dimensions in mm

Sherpa – XS	Annex 2 of European Technical Assessment ETA-12/0067 of 04.06.2018
Product details definitions: <u>Type XS 10 12/30/70</u> Mounting: <u>secondary beam</u>	

electronic copy electronic copy electronic copy electronic copy electronic copy electronic copy electronic copy electronic copy electronic copy electronic copy

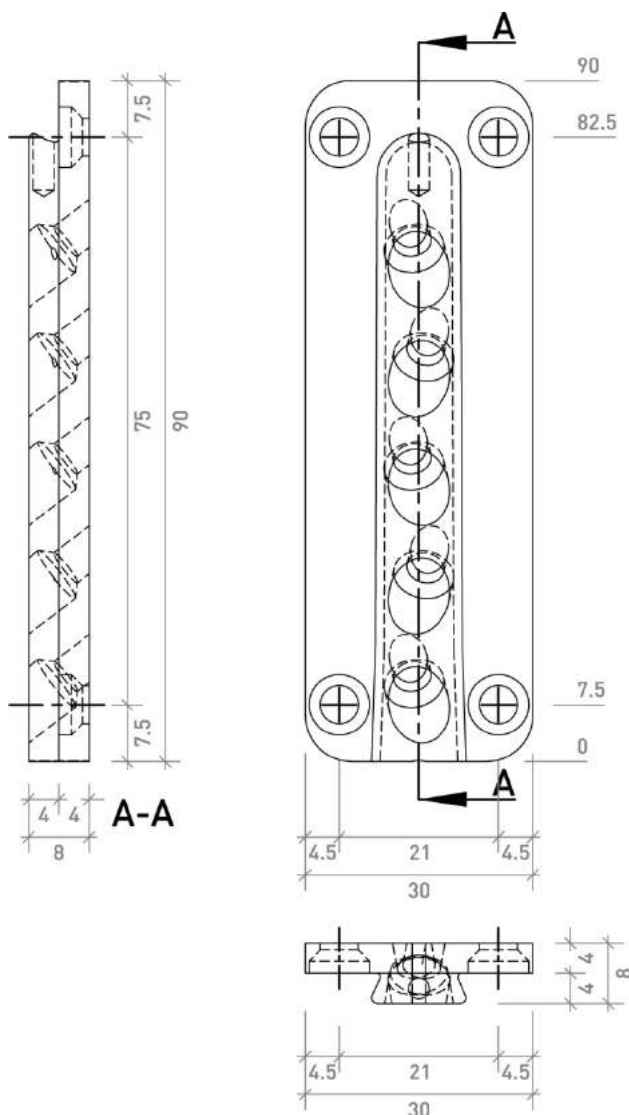

Dimensions in mm

Sherpa – XS

Product details definitions: Type XS 15 12/30/90
 Mounting: main beam or column

Annex 2

of European Technical Assessment
 ETA-12/0067 of 04.06.2018

electronic copy electronic copy electronic copy electronic copy electronic copy electronic copy electronic copy electronic copy electronic copy electronic copy

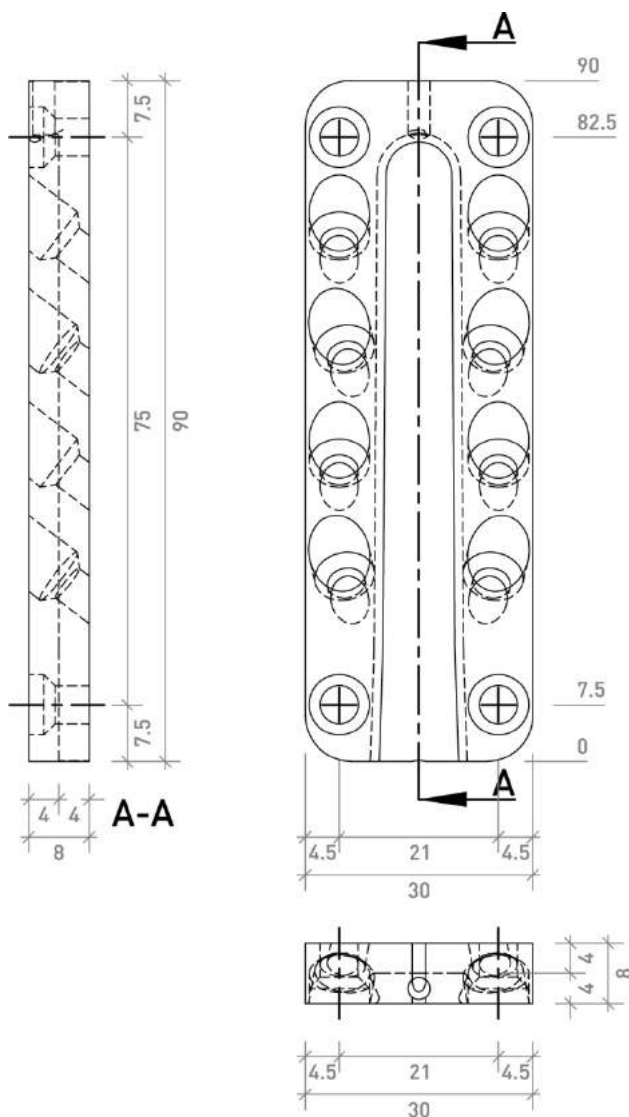

Dimensions in mm

Sherpa – XS	Annex 2 of European Technical Assessment ETA-12/0067 of 04.06.2018
Product details definitions: <u>Type XS 15 12/30/90</u> Mounting: <u>secondary beam</u>	

electronic copy electronic copy electronic copy electronic copy electronic copy electronic copy electronic copy electronic copy electronic copy electronic copy

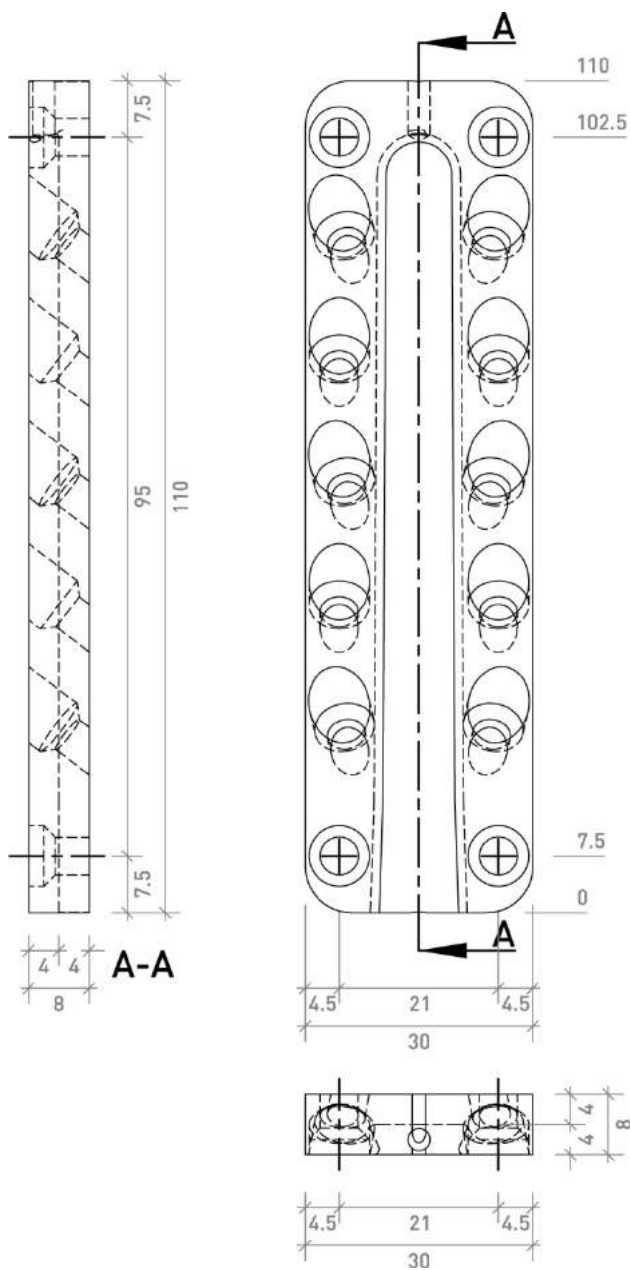

Dimensions in mm

Sherpa – XS

Product details definitions: Type XS 20 12/30/110
 Mounting: secondary beam

Annex 2

of European Technical Assessment
 ETA-12/0067 of 04.06.2018

electronic copy electronic copy electronic copy electronic copy electronic copy electronic copy electronic copy electronic copy electronic copy electronic copy

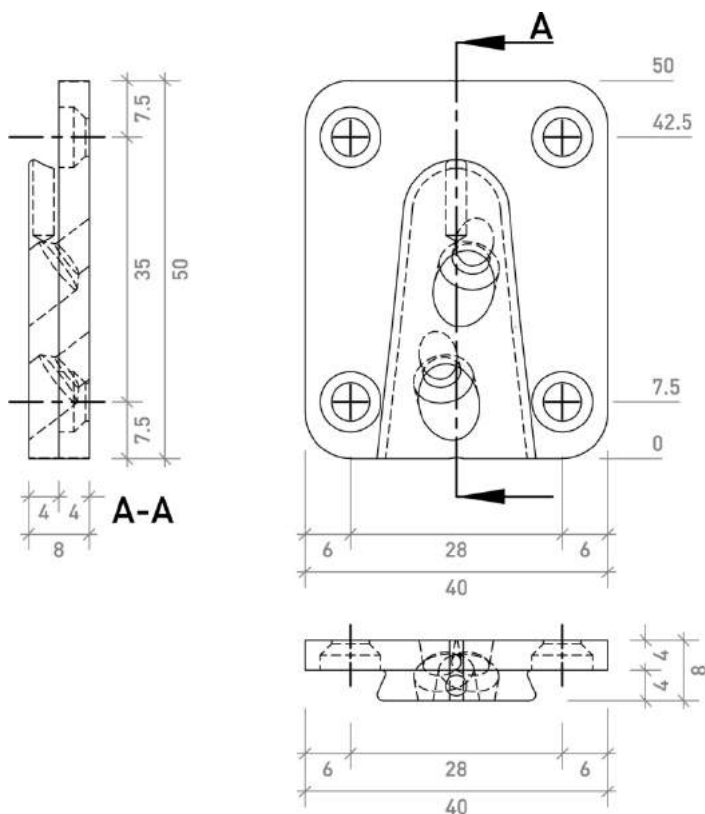

Dimensions in mm

Sherpa – S	Annex 2 of European Technical Assessment ETA-12/0067 of 04.06.2018
Product details definitions: <u>Type S 5 12/40/50</u> Mounting: <u>main beam or column</u>	

electronic copy electronic copy electronic copy electronic copy electronic copy electronic copy electronic copy electronic copy electronic copy electronic copy

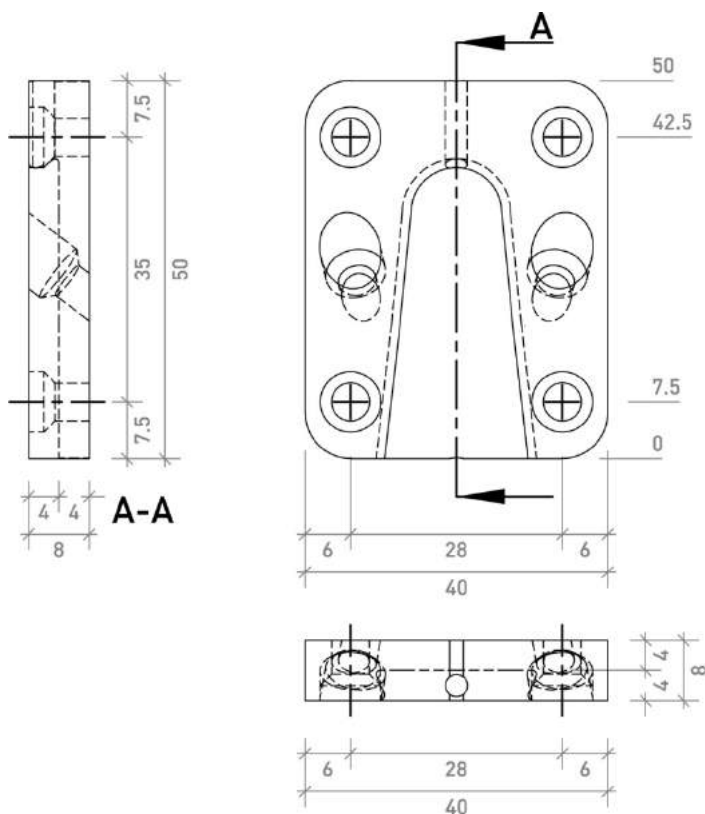

Dimensions in mm

Sherpa – S

Product details definitions: Type S 5 12/40/50
 Mounting: secondary beam

Annex 2

of European Technical Assessment
 ETA-12/0067 of 04.06.2018

electronic copy electronic copy electronic copy electronic copy electronic copy electronic copy electronic copy electronic copy electronic copy electronic copy

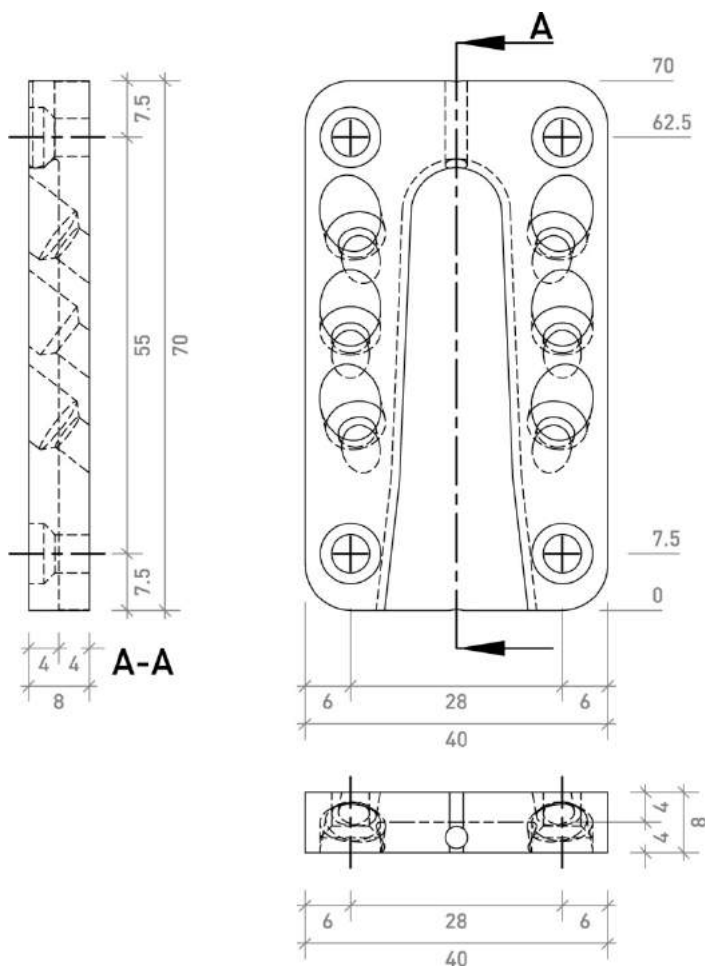

Dimensions in mm

Sherpa – S

Product details definitions: Type S 10 12/40/70
 Mounting: secondary beam

Annex 2

of European Technical Assessment
 ETA-12/0067 of 04.06.2018

electronic copy electronic copy electronic copy electronic copy electronic copy electronic copy electronic copy electronic copy electronic copy electronic copy

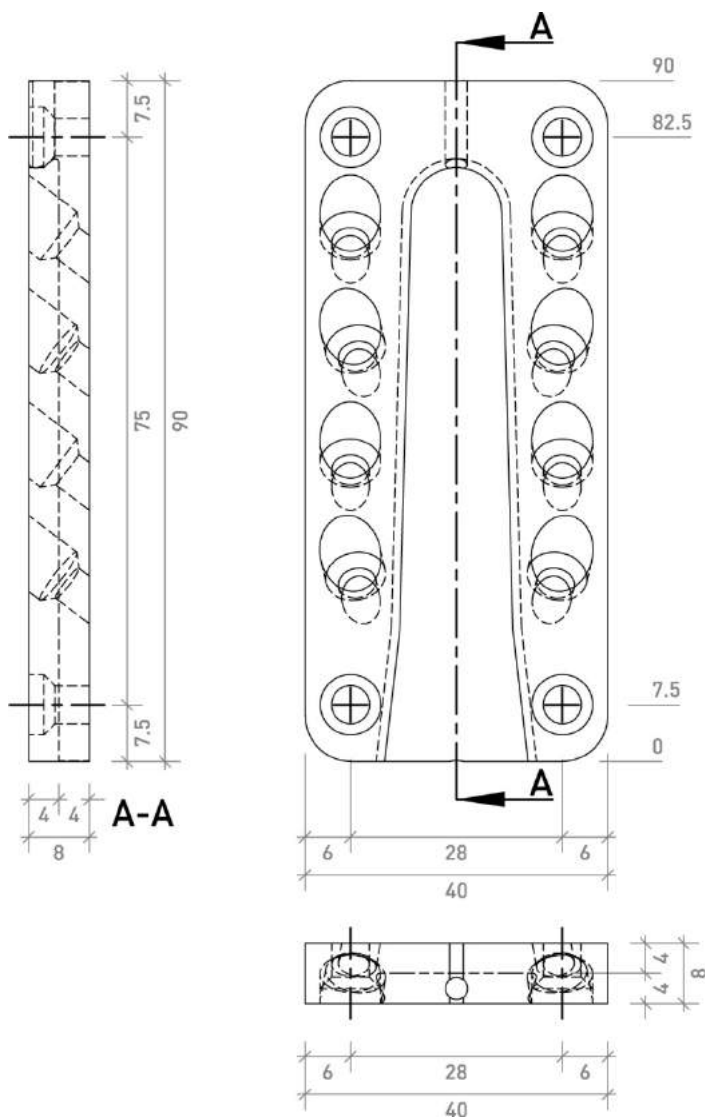

Dimensions in mm

Sherpa – S

Product details definitions: Type S 15 12/40/90
 Mounting: secondary beam

Annex 2

of European Technical Assessment
 ETA-12/0067 of 04.06.2018

electronic copy electronic copy electronic copy electronic copy electronic copy electronic copy electronic copy electronic copy electronic copy electronic copy

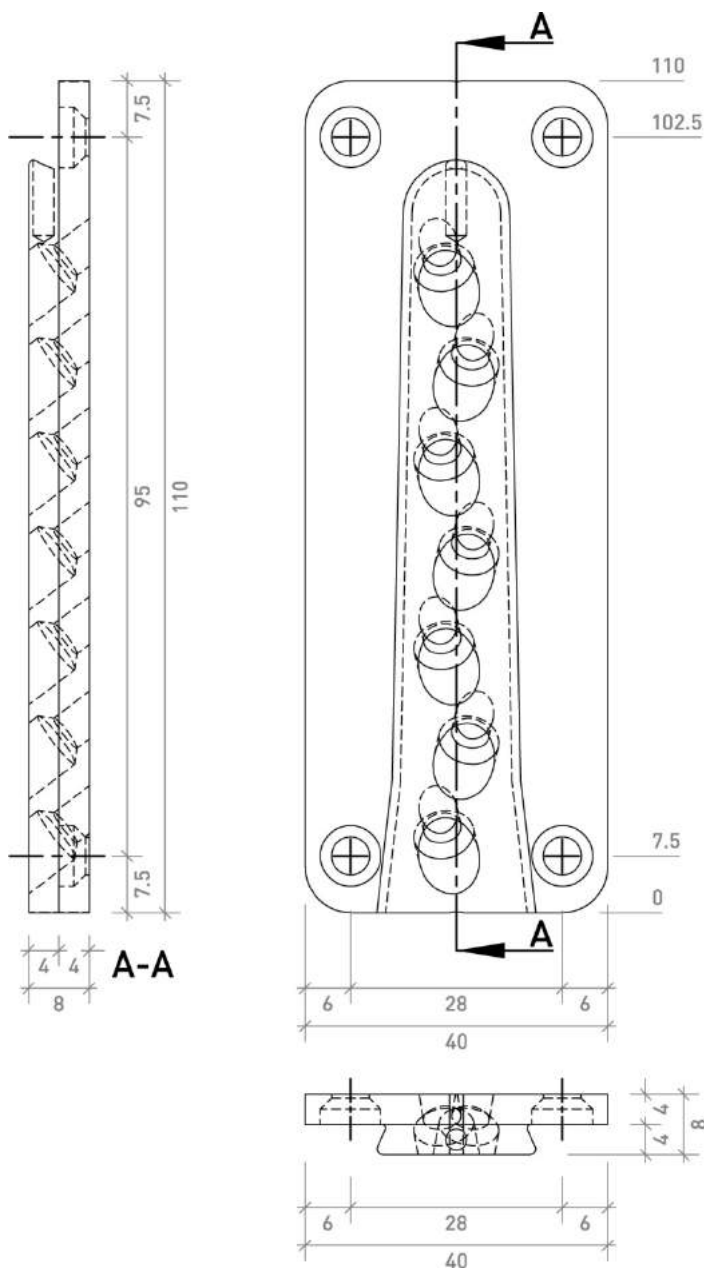

Dimensions in mm

Sherpa – S

Product details definitions: Type S 20 12/40/110
 Mounting: main beam or column

Annex 2

of European Technical Assessment
 ETA-12/0067 of 04.06.2018

electronic copy electronic copy electronic copy electronic copy electronic copy electronic copy electronic copy electronic copy electronic copy electronic copy

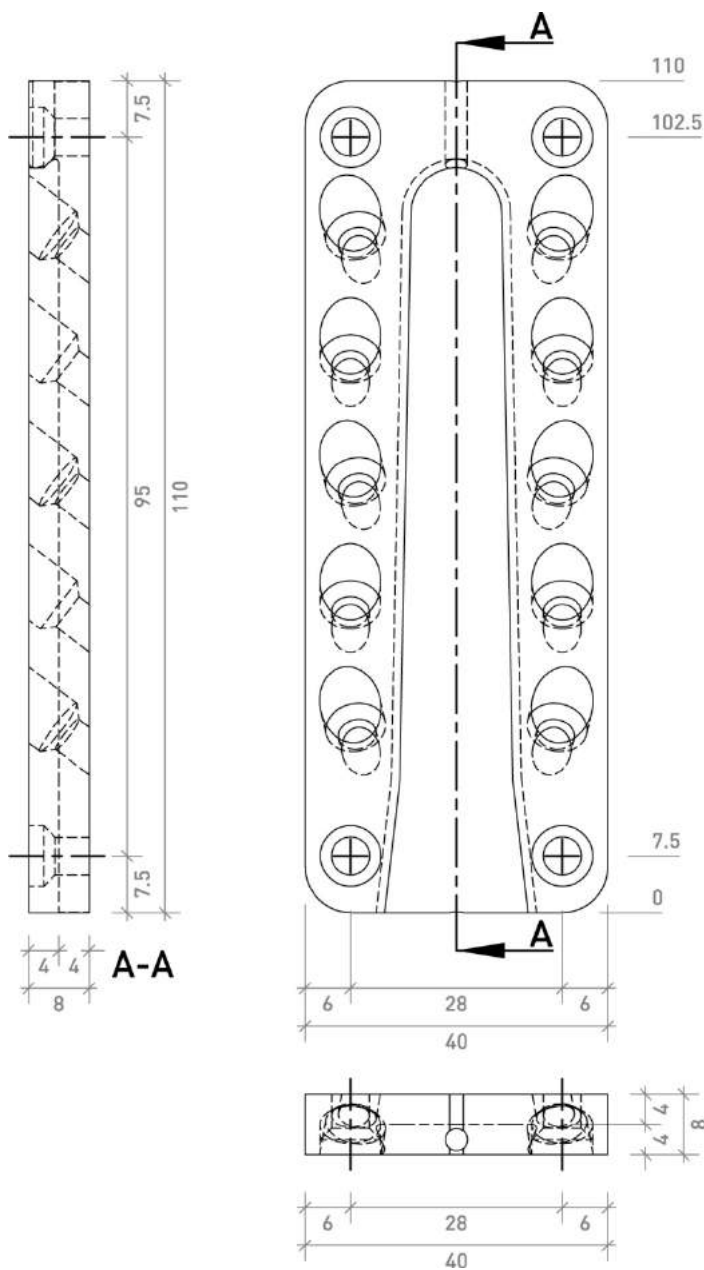

Dimensions in mm

Sherpa – S

Product details definitions: Type S 20 12/40/110
 Mounting: secondary beam

Annex 2

of European Technical Assessment
 ETA-12/0067 of 04.06.2018

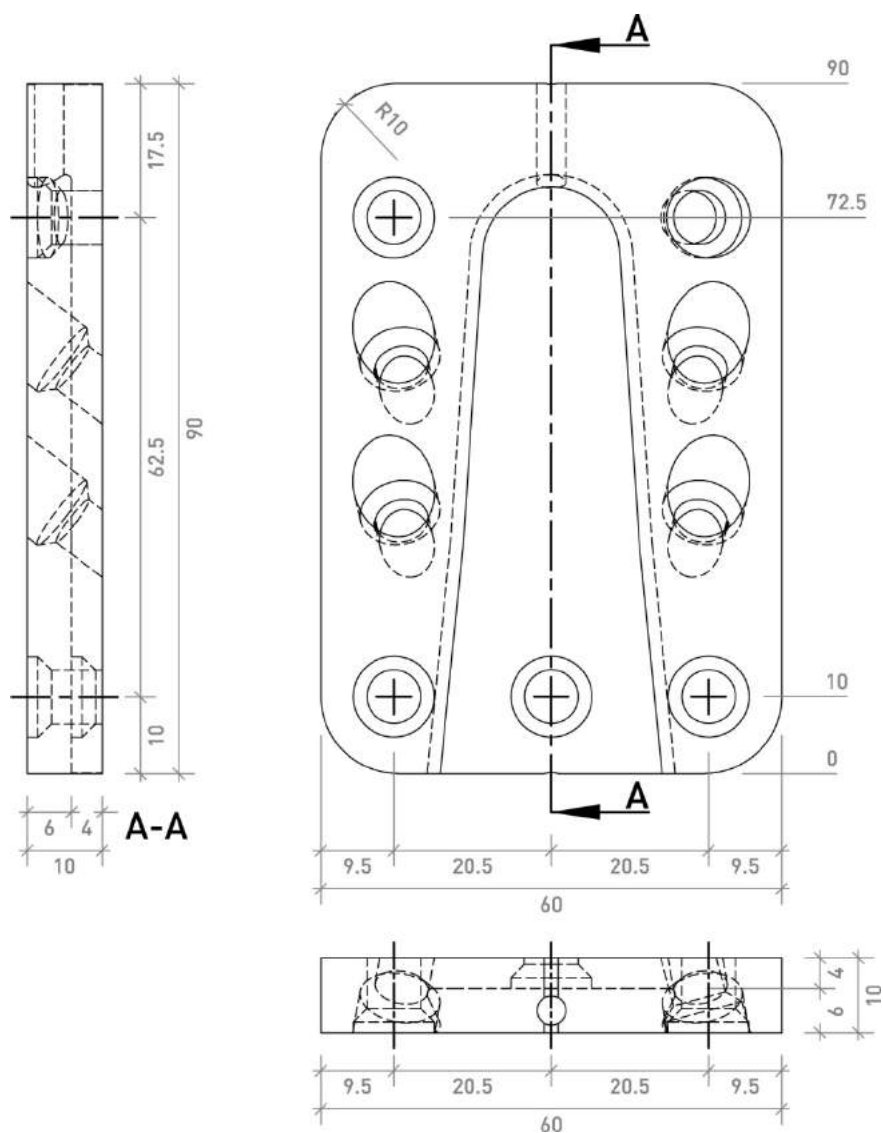

Dimensions in mm

Sherpa – M

Product details definitions: Type M 15 14/60/90
 Mounting: secondary beam

Annex 2

of European Technical Assessment
 ETA-12/0067 of 04.06.2018

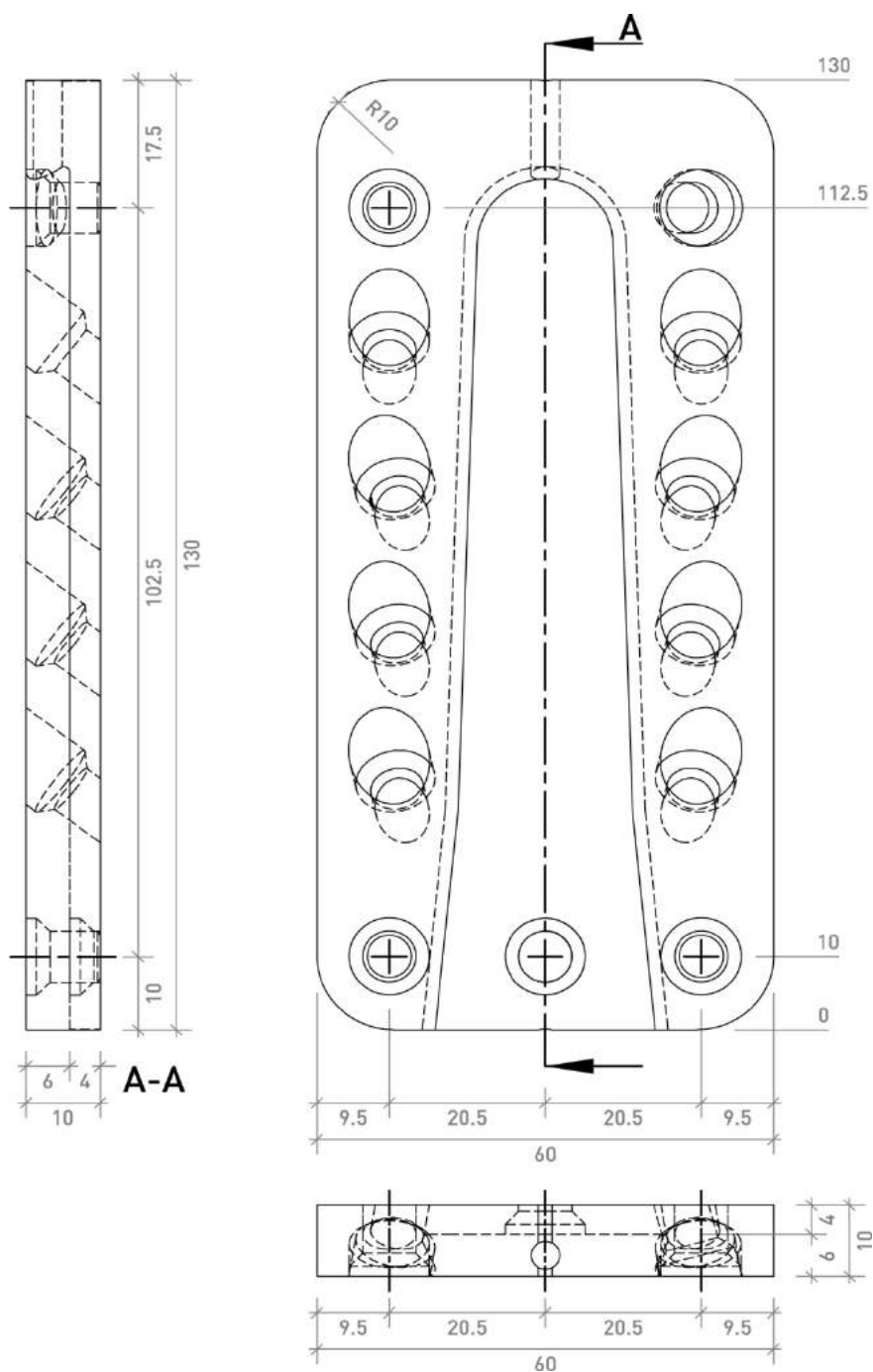

Dimensions in mm

Sherpa – M

Product details definitions: Type M 25 14/60/130
 Mounting: secondary beam

Annex 2

of European Technical Assessment
 ETA-12/0067 of 04.06.2018

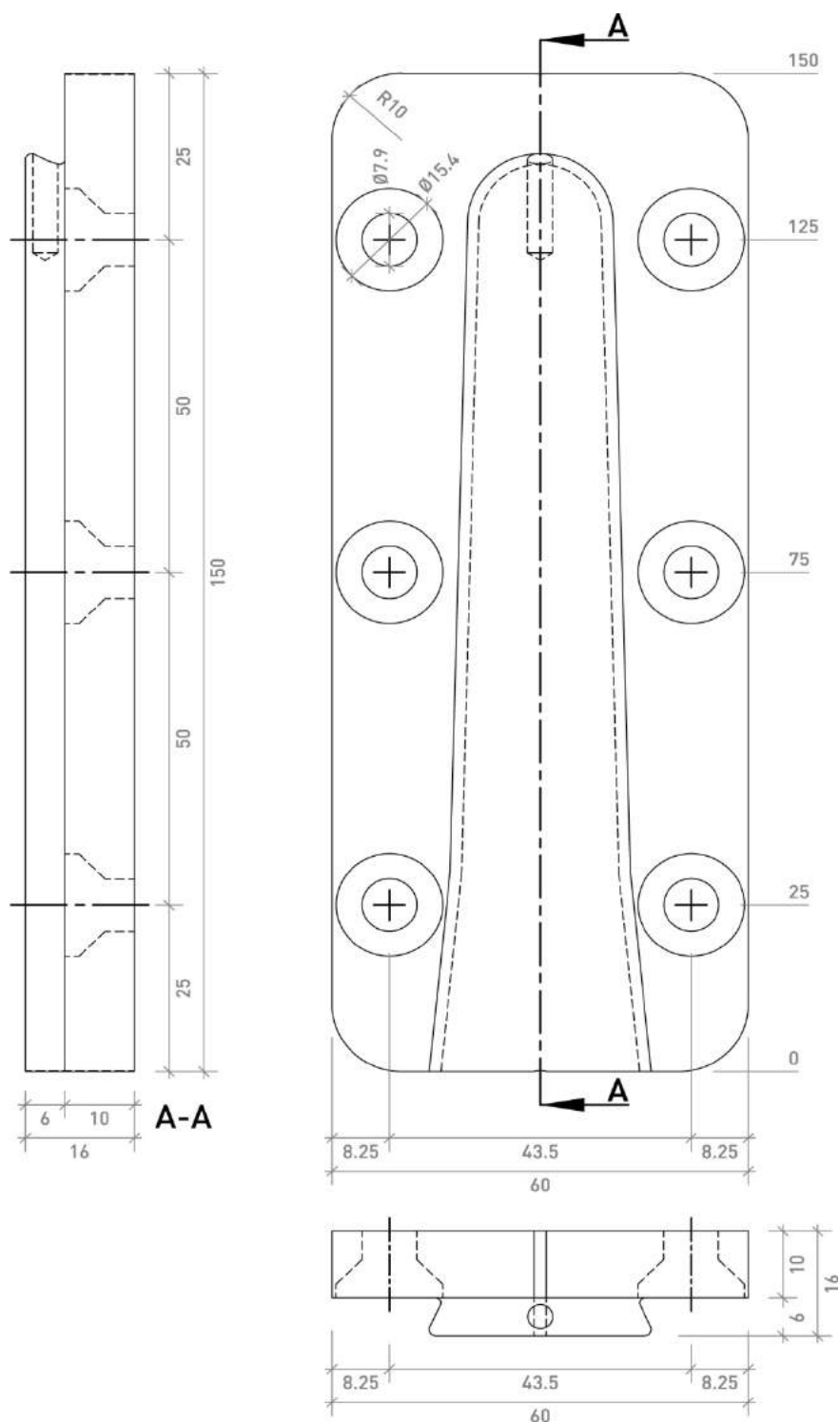

Dimensions in mm

Sherpa – M CS

Product details definitions: Type M 30 CS 14/60/150
 Mounting: main beam or column

Annex 2

of European Technical Assessment
 ETA-12/0067 of 04.06.2018

electronic copy

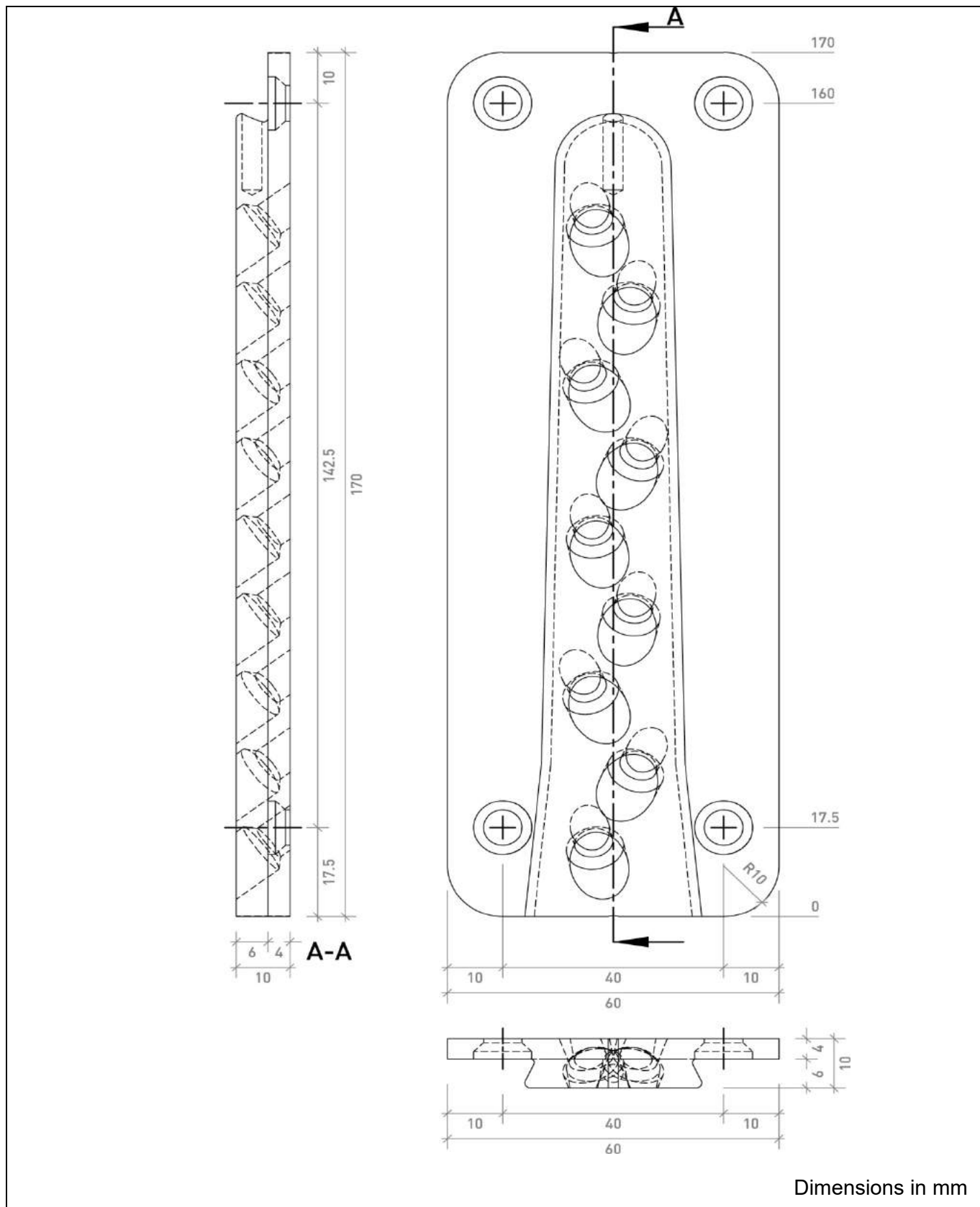

Sherpa – M	Annex 2 of European Technical Assessment ETA-12/0067 of 04.06.2018
Product details definitions: <u>Type M 40 14/60/170</u> Mounting: <u>main beam or column</u>	

electronic copy electronic copy electronic copy electronic copy electronic copy electronic copy electronic copy electronic copy electronic copy electronic copy

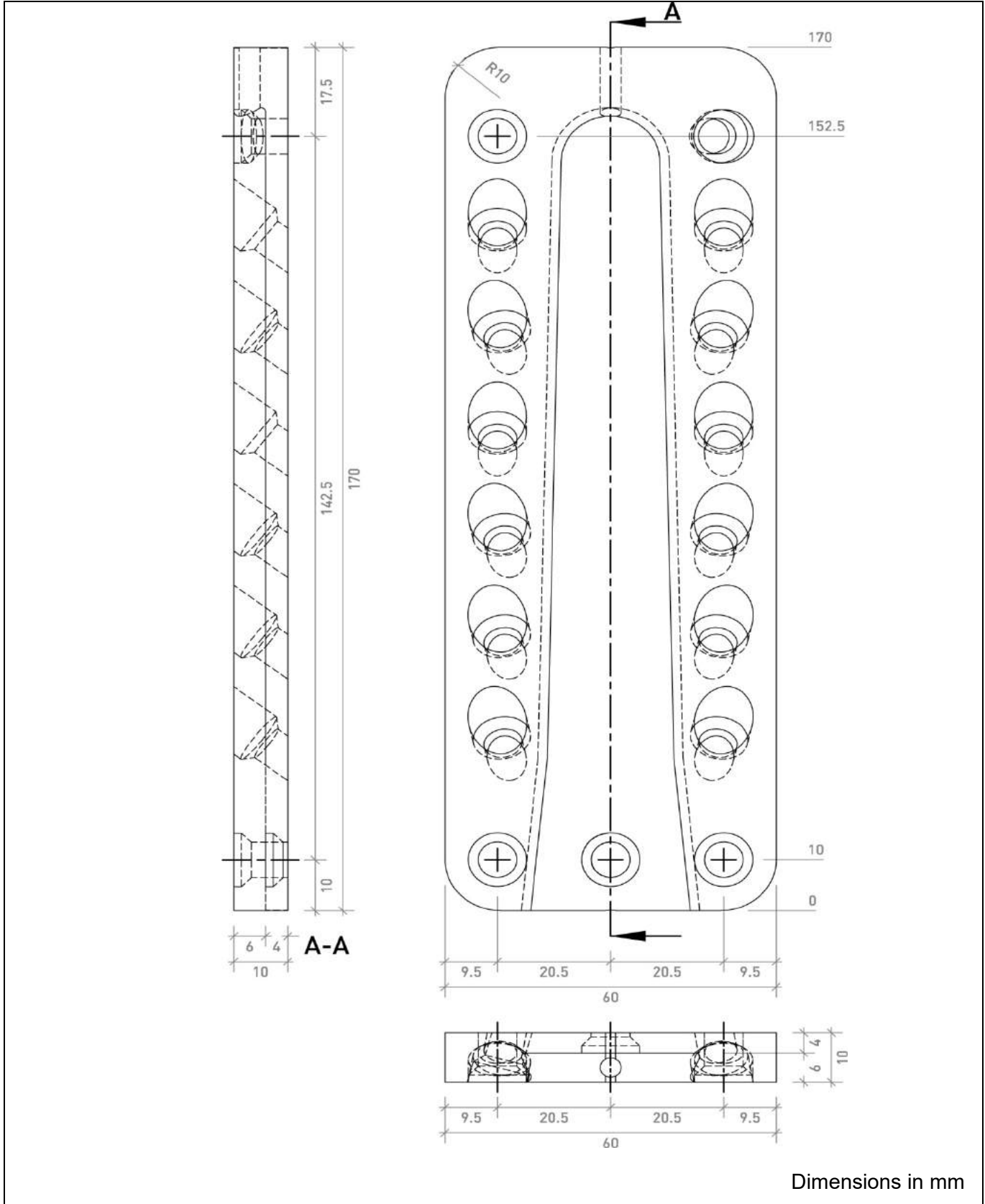

Dimensions in mm

Sherpa – M	Annex 2 of European Technical Assessment ETA-12/0067 of 04.06.2018
Product details definitions: <u>Type M 40 14/60/170</u> Mounting: <u>secondary beam</u>	

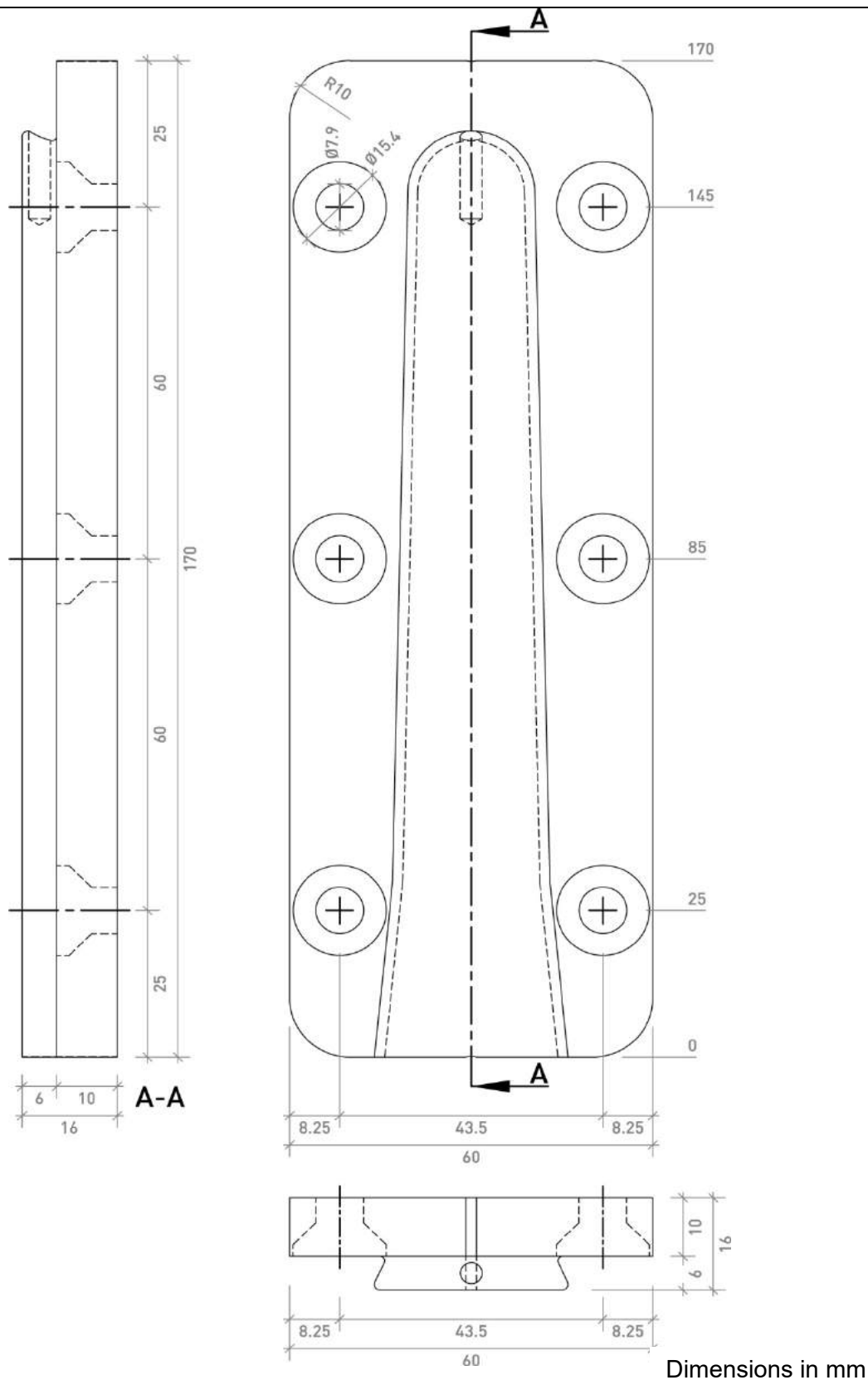

Sherpa – M CS

Product details definitions: Type M 40 CS 14/60/170
 Mounting: main beam or column

Annex 2

of European Technical Assessment
 ETA-12/0067 of 04.06.2018

electronic copy electronic copy electronic copy electronic copy electronic copy electronic copy electronic copy electronic copy electronic copy electronic copy

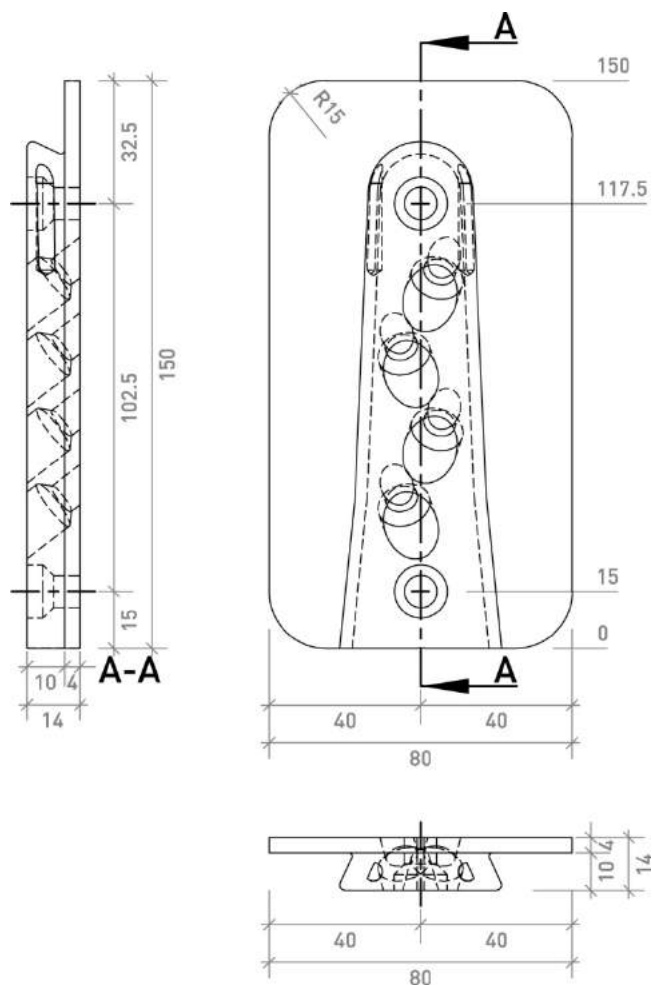

Dimensions in mm

Sherpa – L	Annex 2 of European Technical Assessment ETA-12/0067 of 04.06.2018
Product details definitions: <u>Type L 30 18/80/150</u> Mounting: <u>main beam or column</u>	

electronic copy electronic copy electronic copy electronic copy electronic copy electronic copy electronic copy electronic copy electronic copy electronic copy

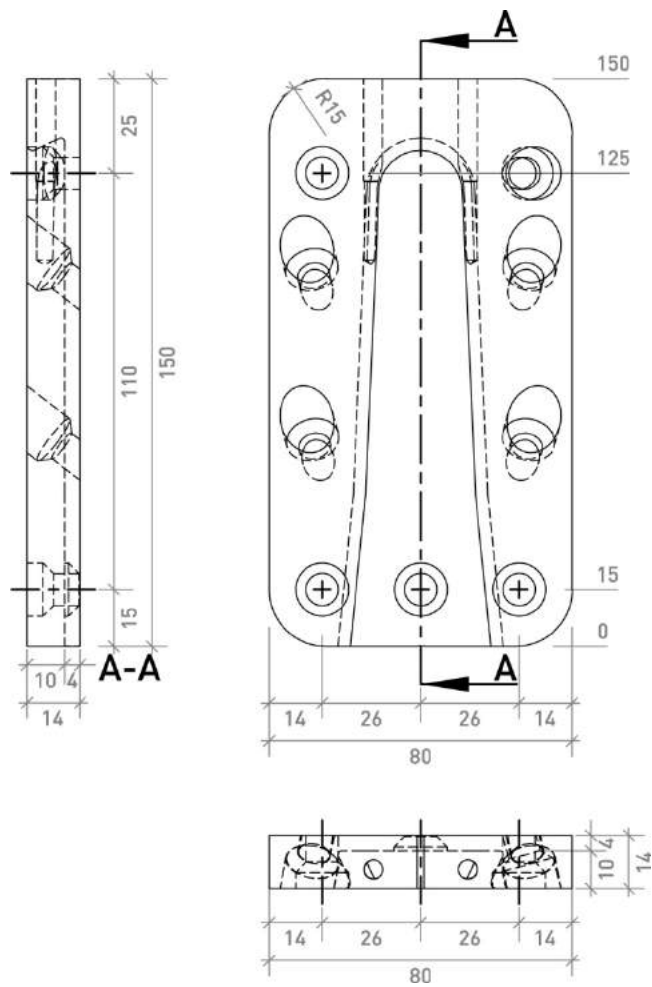

Dimensions in mm

Sherpa – L	Annex 2 of European Technical Assessment ETA-12/0067 of 04.06.2018
Product details definitions: <u>Type L 30 18/80/150</u> Mounting: <u>secondary beam</u>	

electronic copy electronic copy electronic copy electronic copy electronic copy electronic copy electronic copy electronic copy electronic copy electronic copy

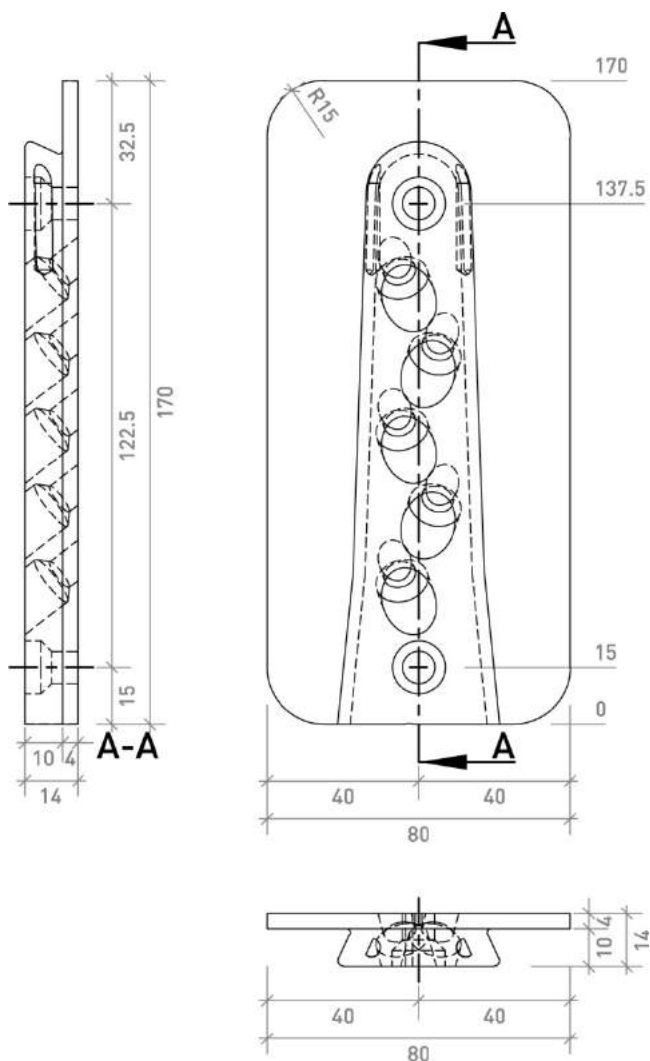

Dimensions in mm

Sherpa – L

Product details definitions: Type L 40 18/80/170
 Mounting: main beam or column

Annex 2

of European Technical Assessment
 ETA-12/0067 of 04.06.2018

electronic copy electronic copy electronic copy electronic copy electronic copy electronic copy electronic copy electronic copy electronic copy electronic copy

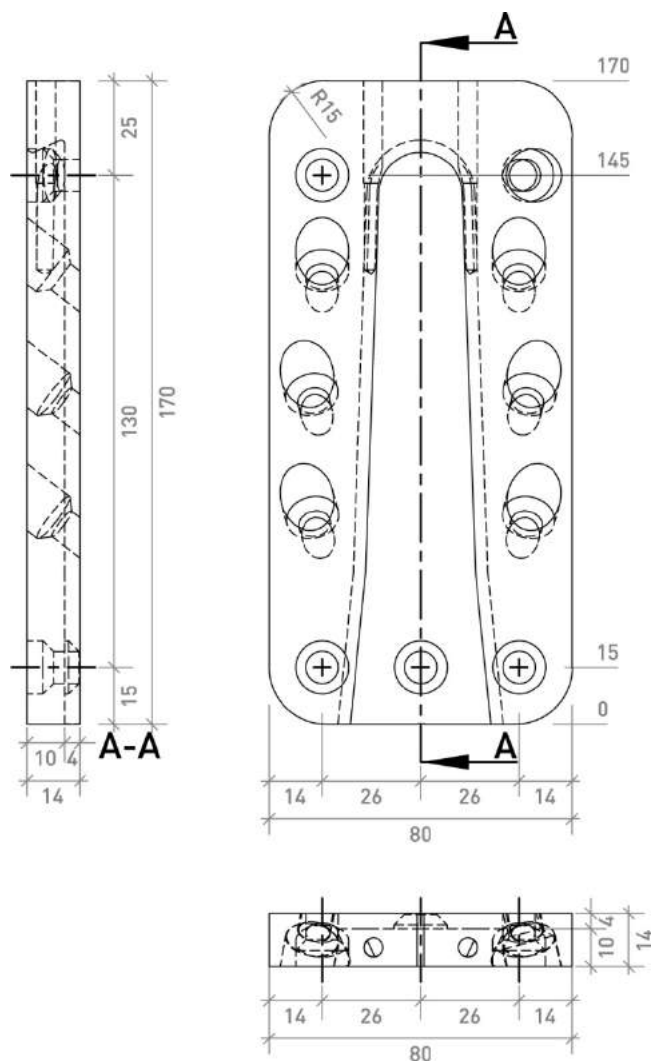

Dimensions in mm

Sherpa – L	Annex 2 of European Technical Assessment ETA-12/0067 of 04.06.2018
Product details definitions: <u>Type L 40 18/80/170</u> Mounting: <u>secondary beam</u>	

electronic copy electronic copy electronic copy electronic copy electronic copy electronic copy electronic copy electronic copy electronic copy electronic copy

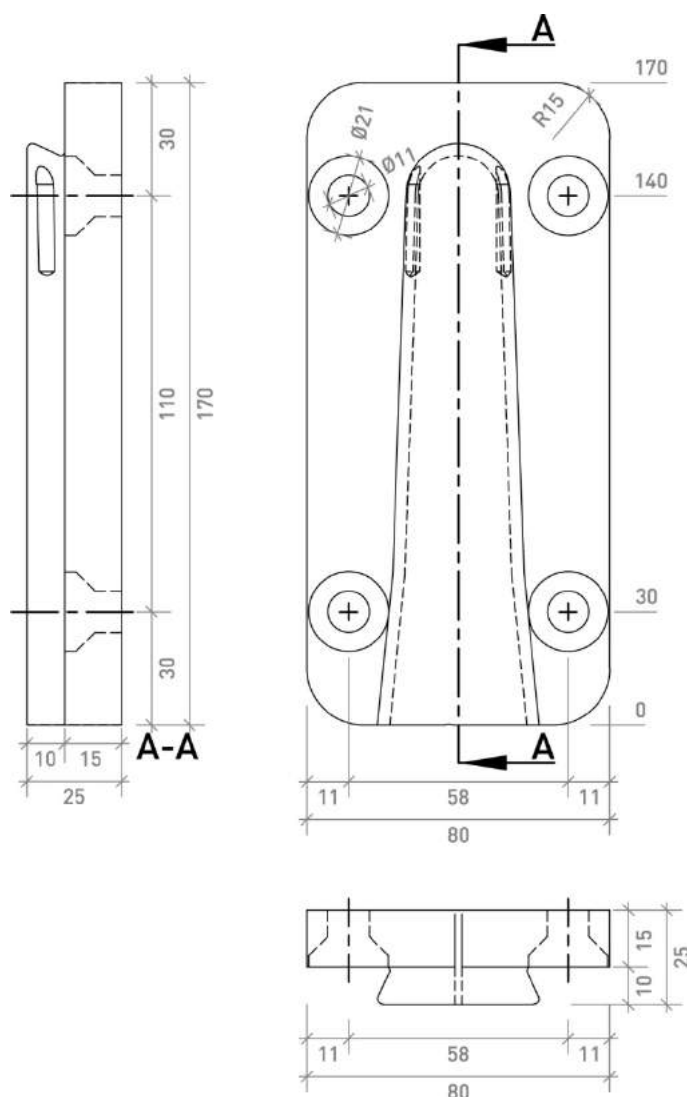

Dimensions in mm

Sherpa – L CS

Product details definitions: Type L 40 CS 18/80/170
 Mounting: main beam or column

Annex 2

of European Technical Assessment
 ETA-12/0067 of 04.06.2018

electronic copy electronic copy electronic copy electronic copy electronic copy electronic copy electronic copy electronic copy electronic copy electronic copy

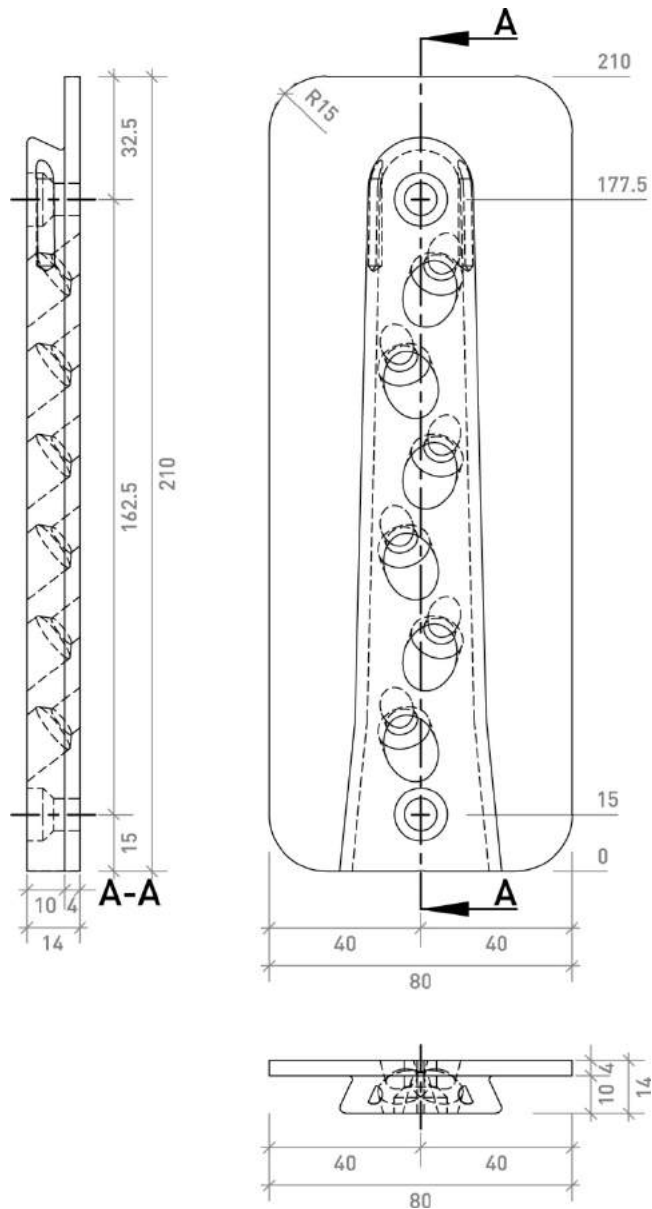

Dimensions in mm

Sherpa - L

Product details definitions: Type L 50 18/80/210
 Mounting: main beam or column

Annex 2

of European Technical Assessment
 ETA-12/0067 of 04.06.2018

electronic copy electronic copy electronic copy electronic copy electronic copy electronic copy electronic copy electronic copy electronic copy electronic copy

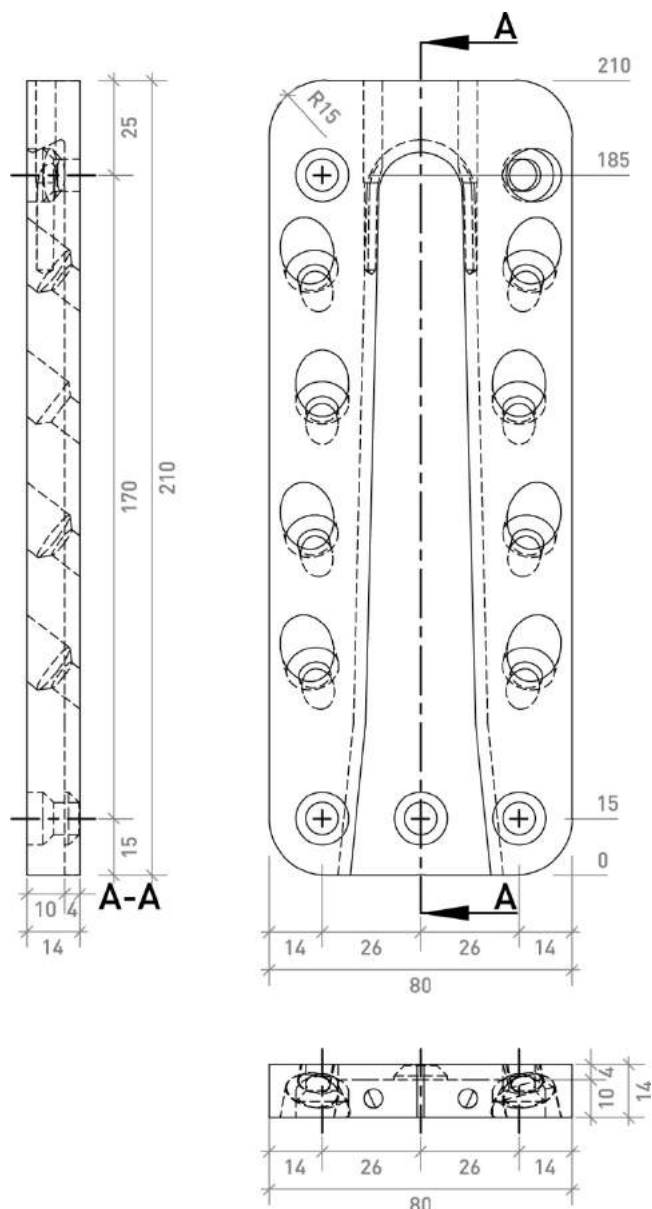

Dimensions in mm

Sherpa - L	Annex 2 of European Technical Assessment ETA-12/0067 of 04.06.2018
Product details definitions: <u>Type L 50 18/80/210</u> Mounting: <u>secondary beam</u>	

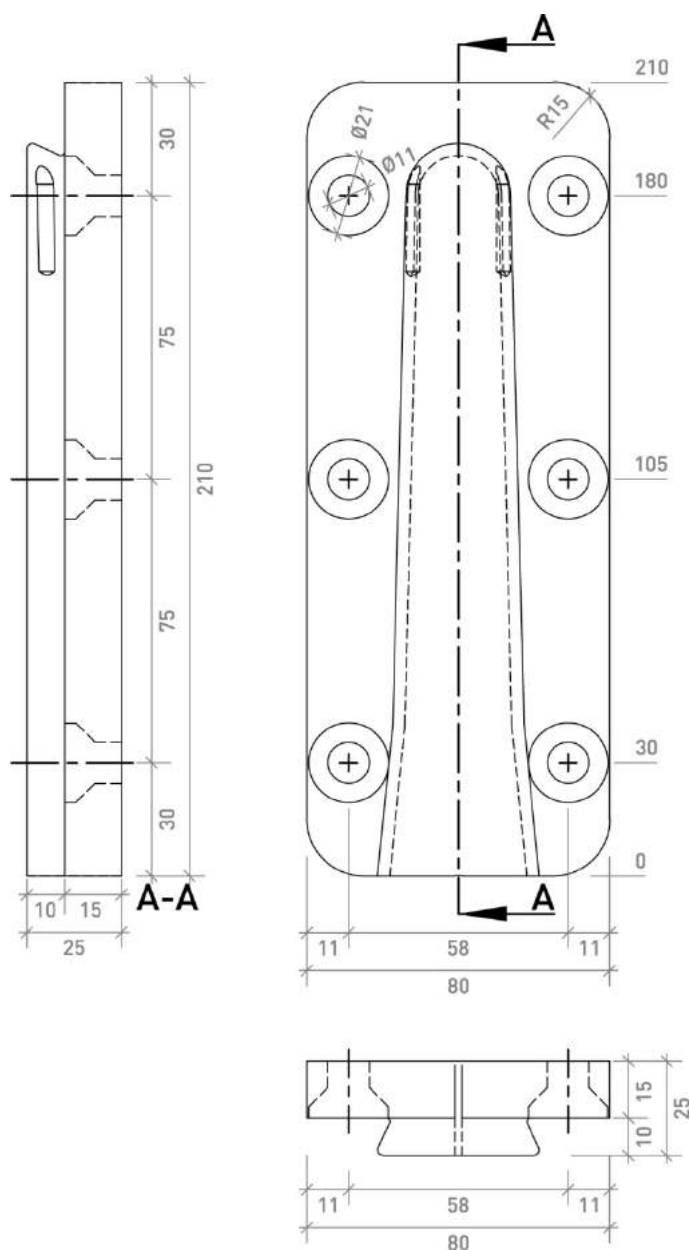

Dimensions in mm

Sherpa – L CS

Product details definitions: Type L 50 CS 18/80/210
 Mounting: main beam or column

Annex 2

of European Technical Assessment
 ETA-12/0067 of 04.06.2018

electronic copy electronic copy electronic copy electronic copy electronic copy electronic copy electronic copy electronic copy electronic copy electronic copy

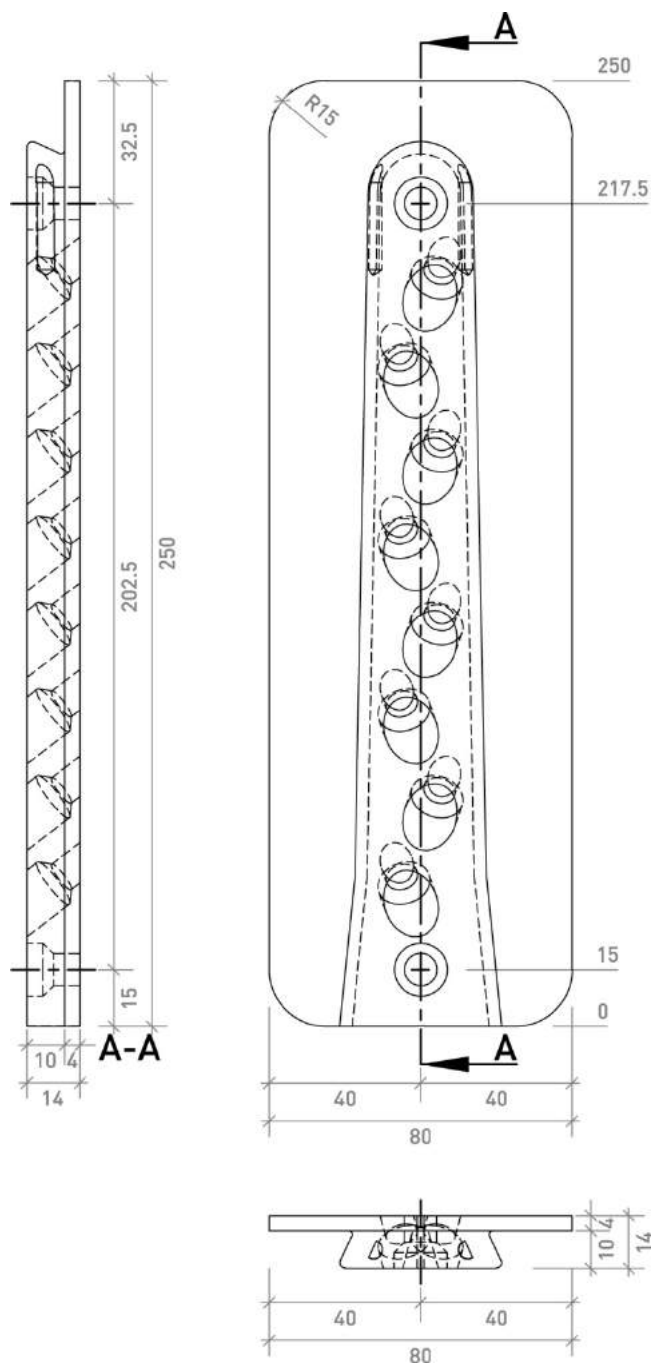

Dimensions in mm

Sherpa - L

Product details definitions: Type L 60 18/80/250
 Mounting: main beam or column

Annex 2

of European Technical Assessment
 ETA-12/0067 of 04.06.2018

electronic copy electronic copy electronic copy electronic copy electronic copy electronic copy electronic copy electronic copy electronic copy electronic copy

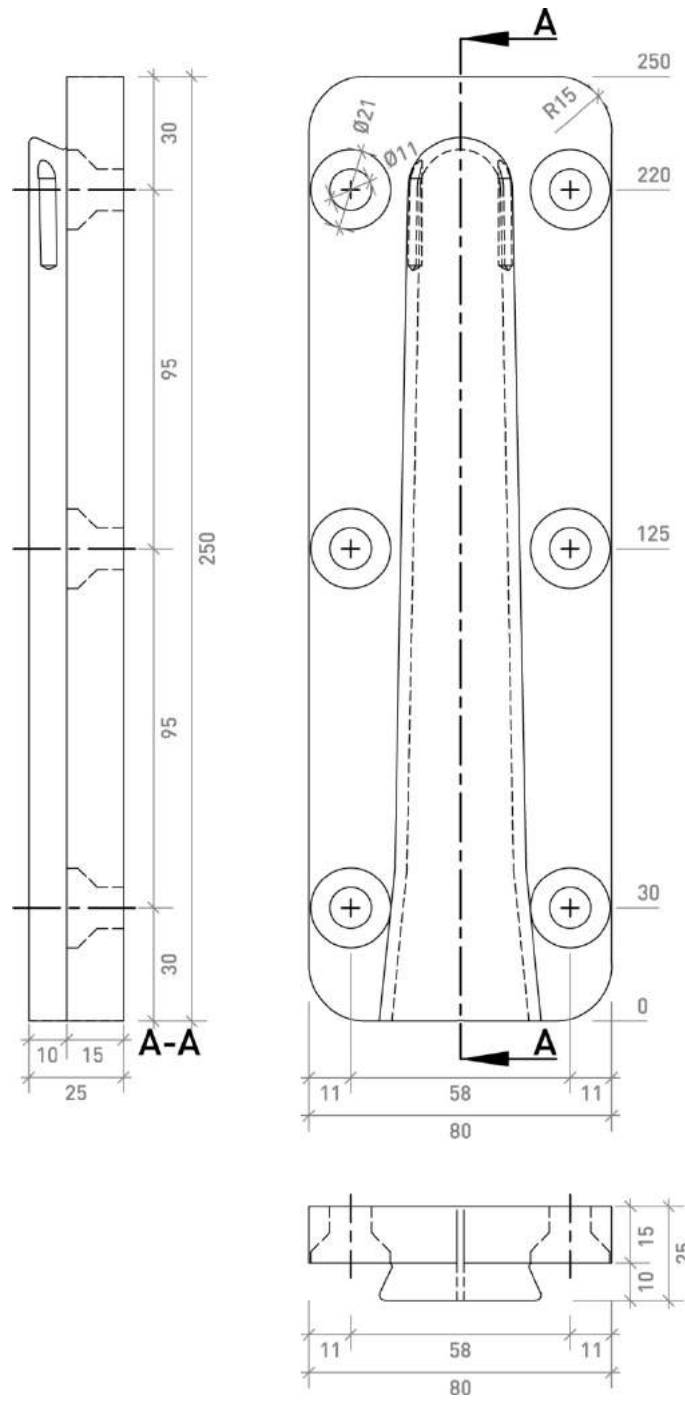

Dimensions in mm

Sherpa – L CS

Product details definitions: Type L 60 CS 18/80/250
 Mounting: main beam or column

Annex 2

of European Technical Assessment
 ETA-12/0067 of 04.06.2018

electronic copy

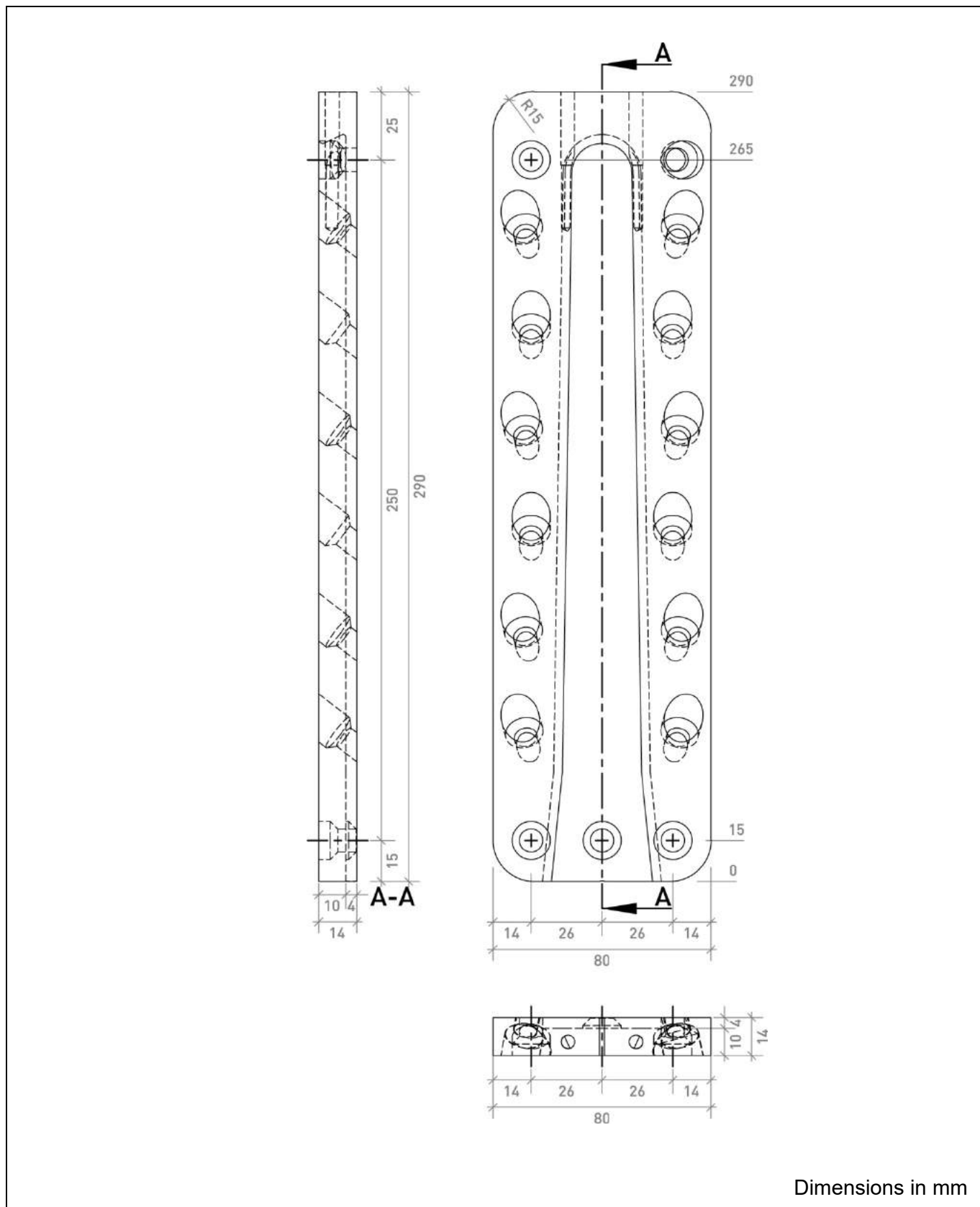

Dimensions in mm

Sherpa - L

Product details definitions: Type L 80 18/80/290
 Mounting: secondary beam

Annex 2

of European Technical Assessment
 ETA-12/0067 of 04.06.2018

electronic copy

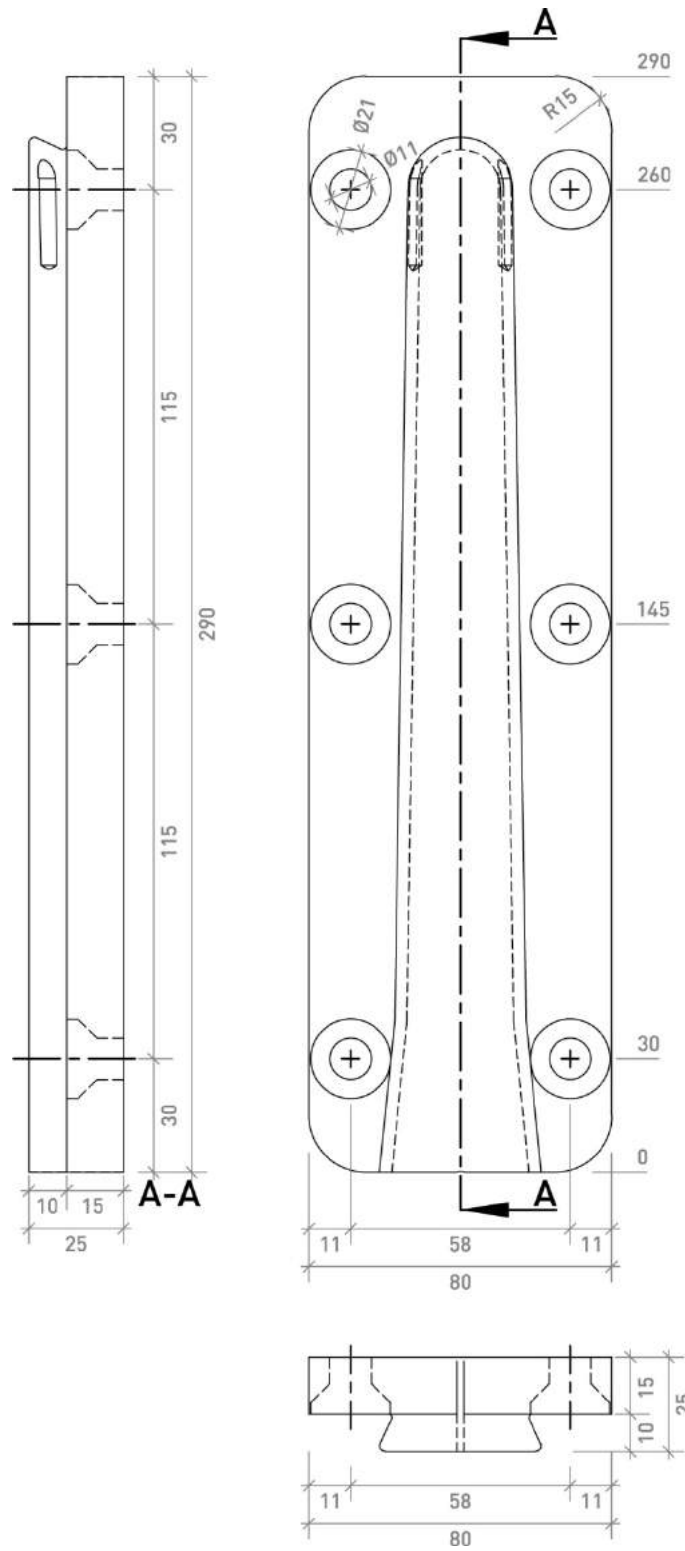

Dimensions in mm

Sherpa – L CS	Annex 2 of European Technical Assessment ETA-12/0067 of 04.06.2018
Product details definitions: <u>Type L 80 CS 18/80/290</u> Mounting: <u>main beam or column</u>	

electronic copy electronic copy electronic copy electronic copy electronic copy electronic copy electronic copy electronic copy electronic copy electronic copy

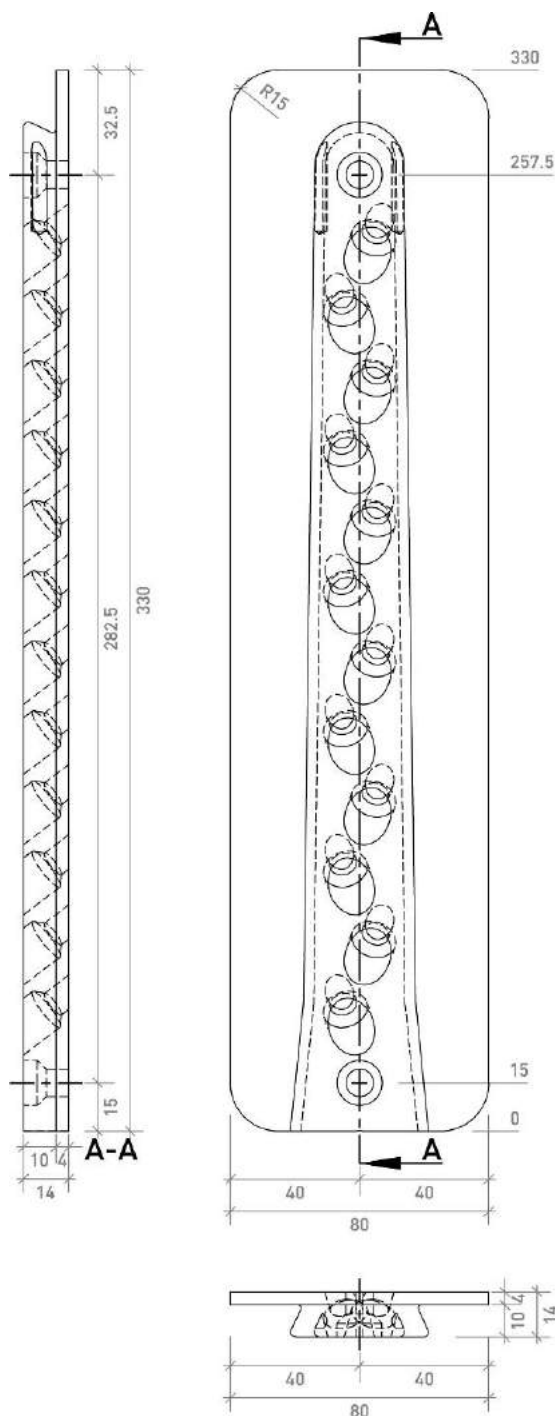

Dimensions in mm

Sherpa – L	Annex 2 of European Technical Assessment ETA-12/0067 of 04.06.2018
Product details definitions: <u>Type L 100 18/80/330</u> Mounting: <u>main beam or column</u>	

electronic copy electronic copy electronic copy electronic copy electronic copy electronic copy electronic copy electronic copy electronic copy electronic copy

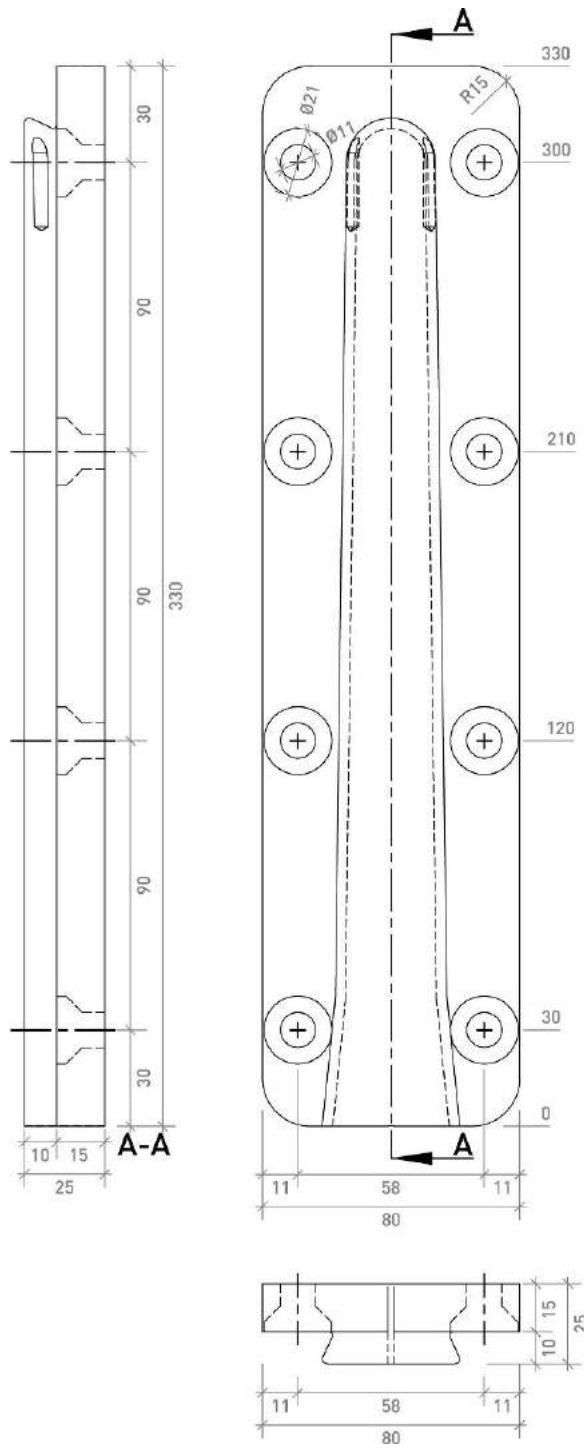

Dimensions in mm

Sherpa – L CS	Annex 2 of European Technical Assessment ETA-12/0067 of 04.06.2018
Product details definitions: <u>Type L CS 100 29/80/330</u> Mounting: <u>main beam or column</u>	

electronic copy electronic copy electronic copy electronic copy electronic copy electronic copy electronic copy electronic copy electronic copy electronic copy

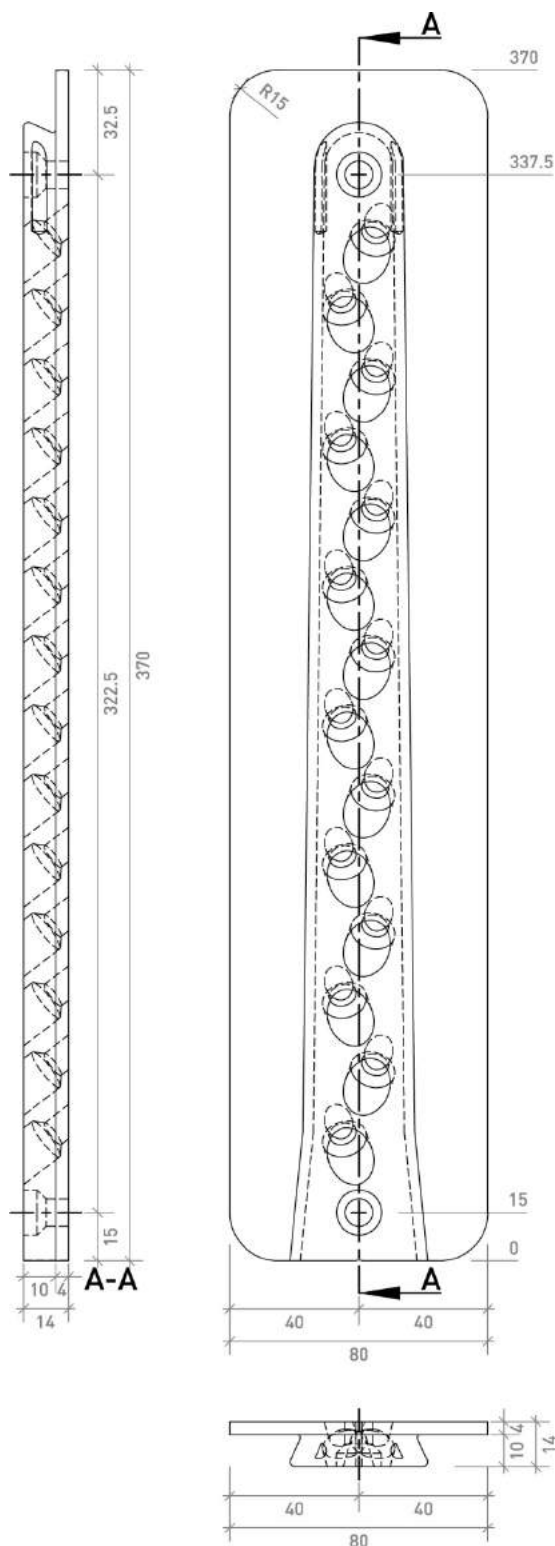

Dimensions in mm

Sherpa – L	Annex 2 of European Technical Assessment ETA-12/0067 of 04.06.2018
Product details definitions: <u>Type L 120 18/80/370</u> Mounting: <u>main beam or column</u>	

electronic copy electronic copy electronic copy electronic copy electronic copy electronic copy electronic copy electronic copy electronic copy electronic copy

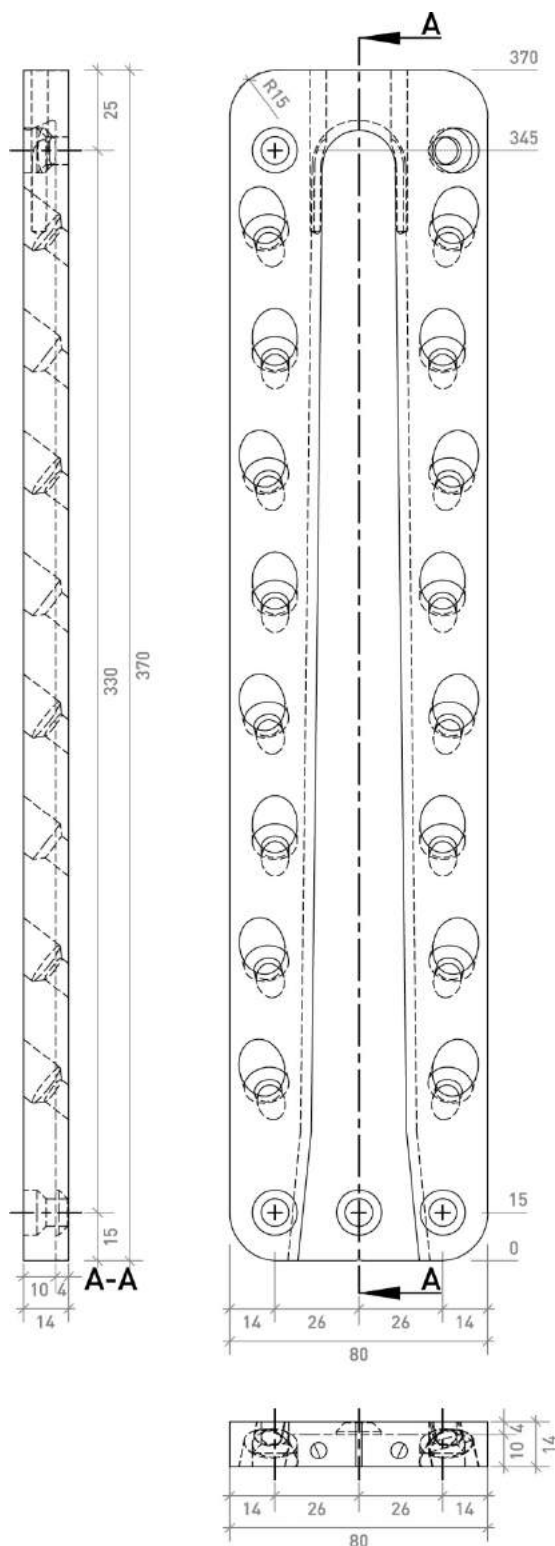

Dimensions in mm

Sherpa – L

Product details definitions: Type L 120 18/80/370
 Mounting: secondary beam

Annex 2

of European Technical Assessment
 ETA-12/0067 of 04.06.2018

electronic copy electronic copy electronic copy electronic copy electronic copy electronic copy electronic copy electronic copy electronic copy electronic copy

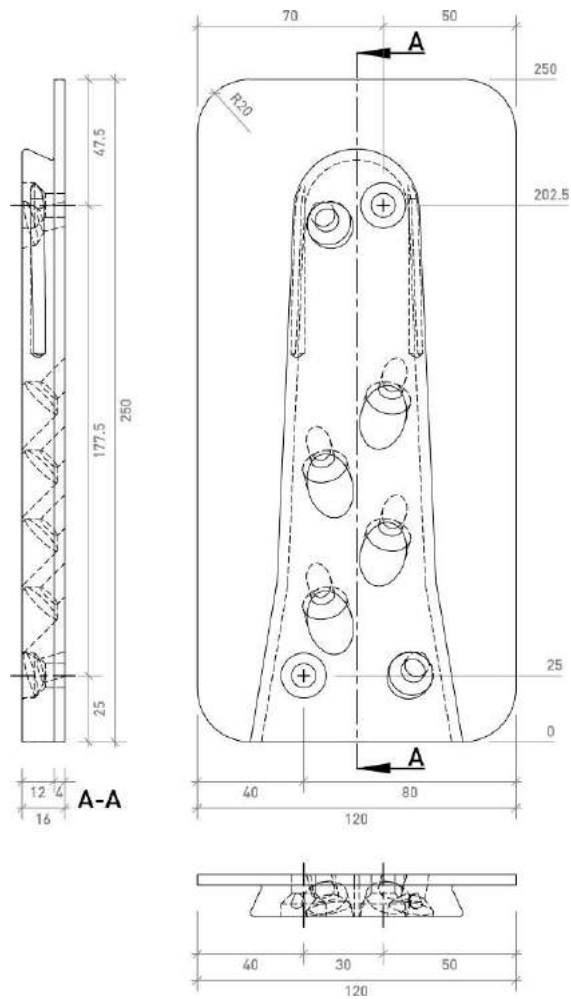

Dimensions in mm

Sherpa – XL

Product details definitions: Type XL 55 20/120/250
 Mounting: main beam or column

Annex 2

of European Technical Assessment
 ETA-12/0067 of 04.06.2018

electronic copy electronic copy electronic copy electronic copy electronic copy electronic copy electronic copy electronic copy electronic copy electronic copy

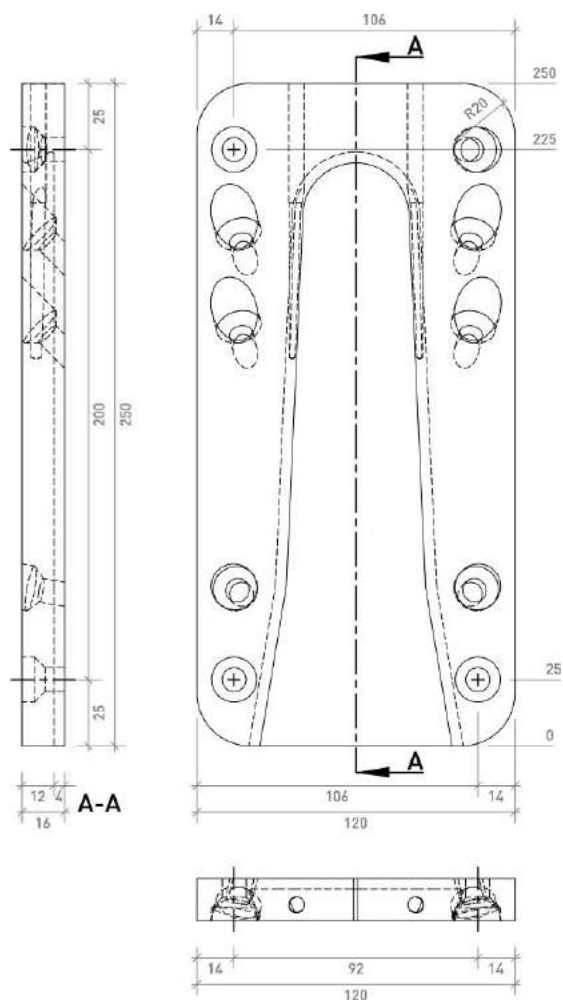

Dimensions in mm

Sherpa – XL

Product details definitions: Type XL 55 20/120/250
 Mounting: secondary beam

Annex 2

of European Technical Assessment
 ETA-12/0067 of 04.06.2018

electronic copy electronic copy electronic copy electronic copy electronic copy electronic copy electronic copy electronic copy electronic copy electronic copy

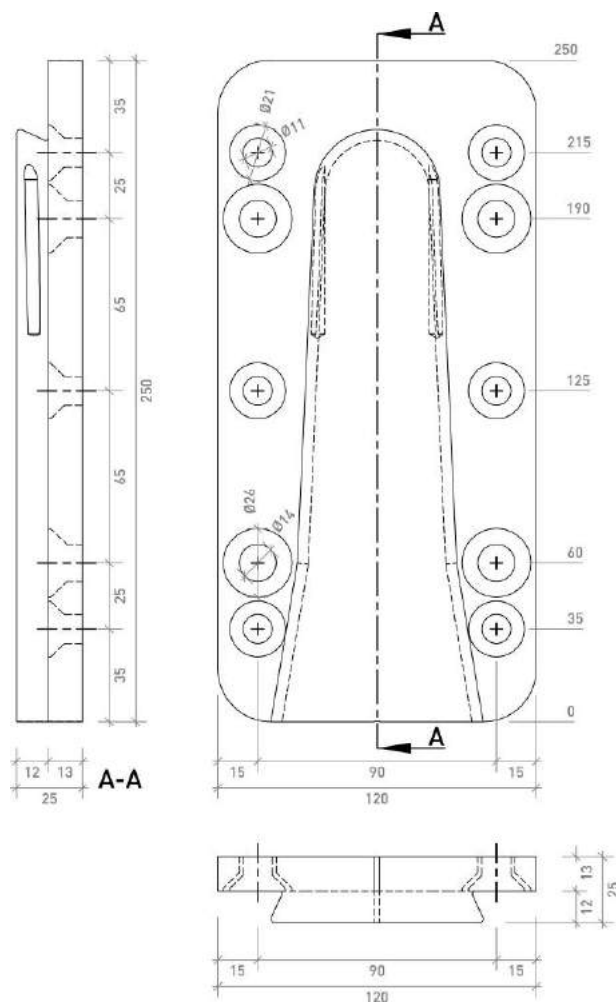

Dimensions in mm

Sherpa – XL CS

Product details definitions: Type XL 55 CS 29/120/250
 Mounting: main beam or column

Annex 2

of European Technical Assessment
 ETA-12/0067 of 04.06.2018

electronic copy electronic copy electronic copy electronic copy electronic copy electronic copy electronic copy electronic copy electronic copy electronic copy

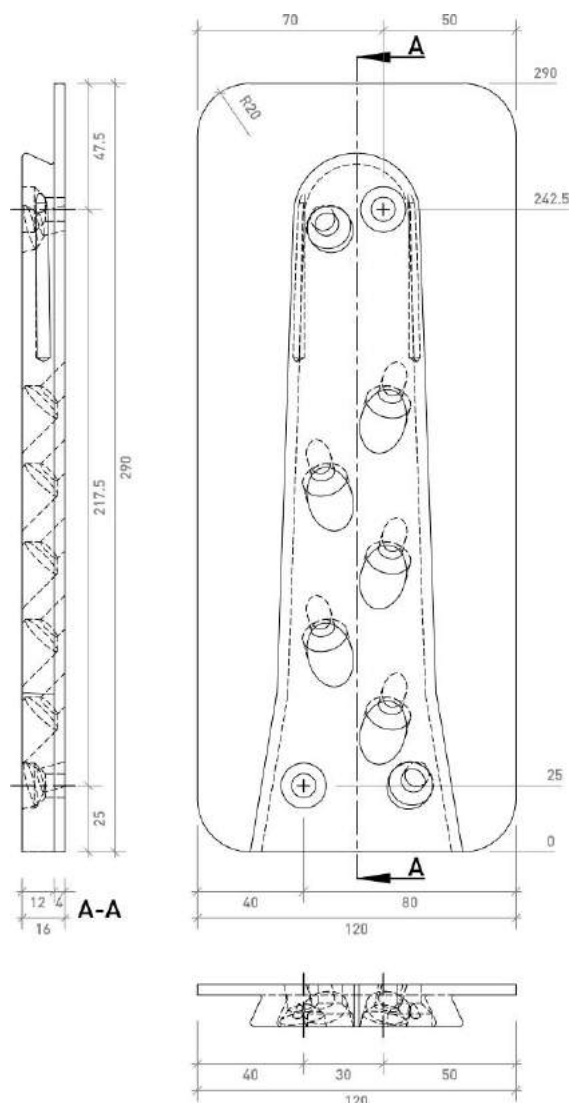

Dimensions in mm

Sherpa – XL

Product details definitions: Type XL 70 20/120/290
 Mounting: main beam or column

Annex 2

of European Technical Assessment
 ETA-12/0067 of 04.06.2018

electronic copy electronic copy electronic copy electronic copy electronic copy electronic copy electronic copy electronic copy electronic copy electronic copy

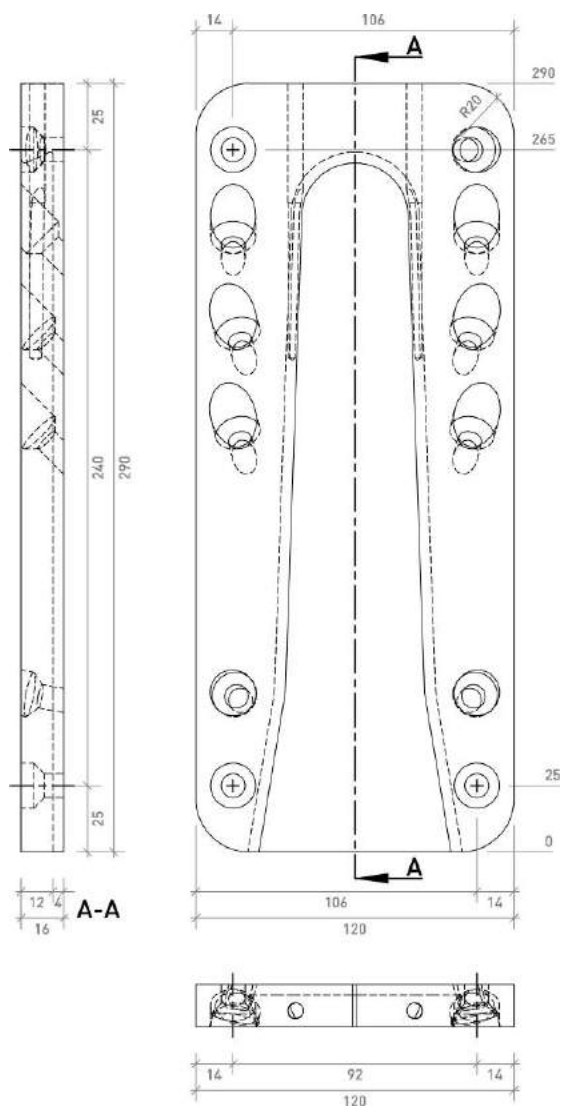

Dimensions in mm

Sherpa – XL

Product details definitions: Type XL 70 20/120/290
 Mounting: secondary beam

Annex 2

of European Technical Assessment
 ETA-12/0067 of 04.06.2018

electronic copy electronic copy electronic copy electronic copy electronic copy electronic copy electronic copy electronic copy electronic copy electronic copy

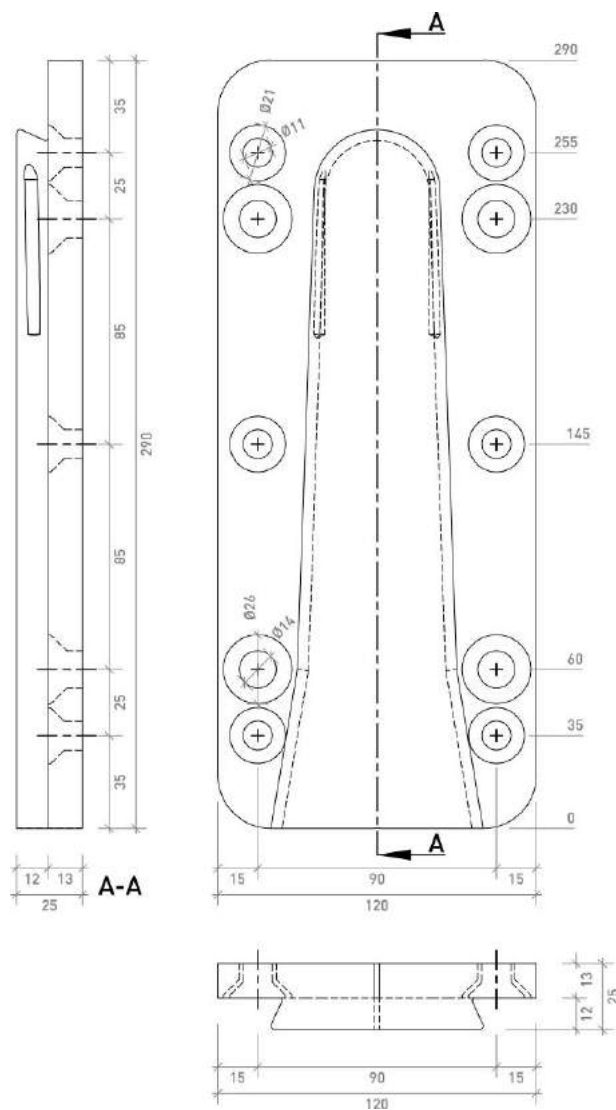

Dimensions in mm

Sherpa – XL CS

Product details definitions: Type XL CS 70 29/120/290
 Mounting: main beam or column

Annex 2

of European Technical Assessment
 ETA-12/0067 of 04.06.2018

electronic copy electronic copy electronic copy electronic copy electronic copy electronic copy electronic copy electronic copy electronic copy electronic copy

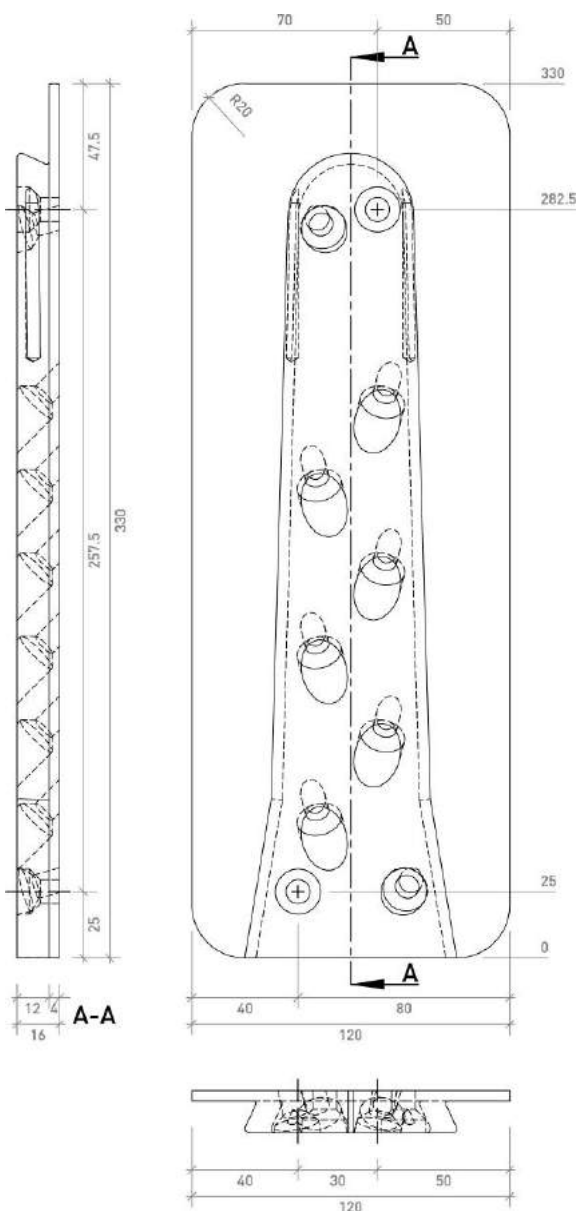

Dimensions in mm

Sherpa – XL

Product details definitions: Type XL 80 20/120/330
 Mounting: main beam or column

Annex 2

of European Technical Assessment
 ETA-12/0067 of 04.06.2018

electronic copy electronic copy electronic copy electronic copy electronic copy electronic copy electronic copy electronic copy electronic copy electronic copy

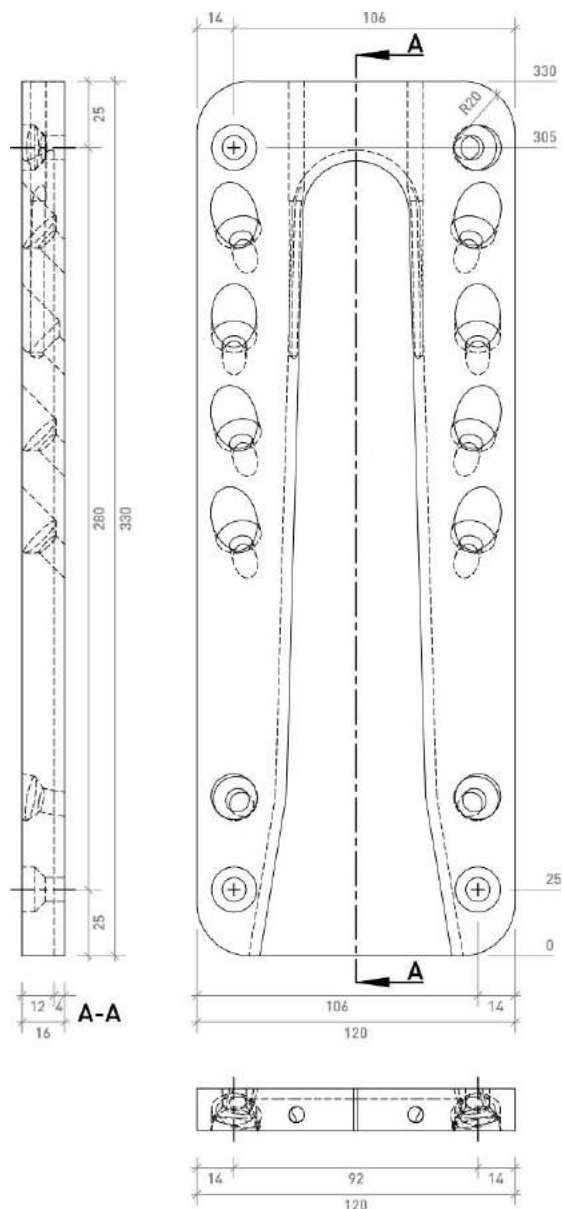

Dimensions in mm

Sherpa – XL

Product details definitions: Type XL 80 20/120/330
 Mounting: secondary beam

Annex 2

of European Technical Assessment
 ETA-12/0067 of 04.06.2018

electronic copy electronic copy electronic copy electronic copy electronic copy electronic copy electronic copy electronic copy electronic copy electronic copy

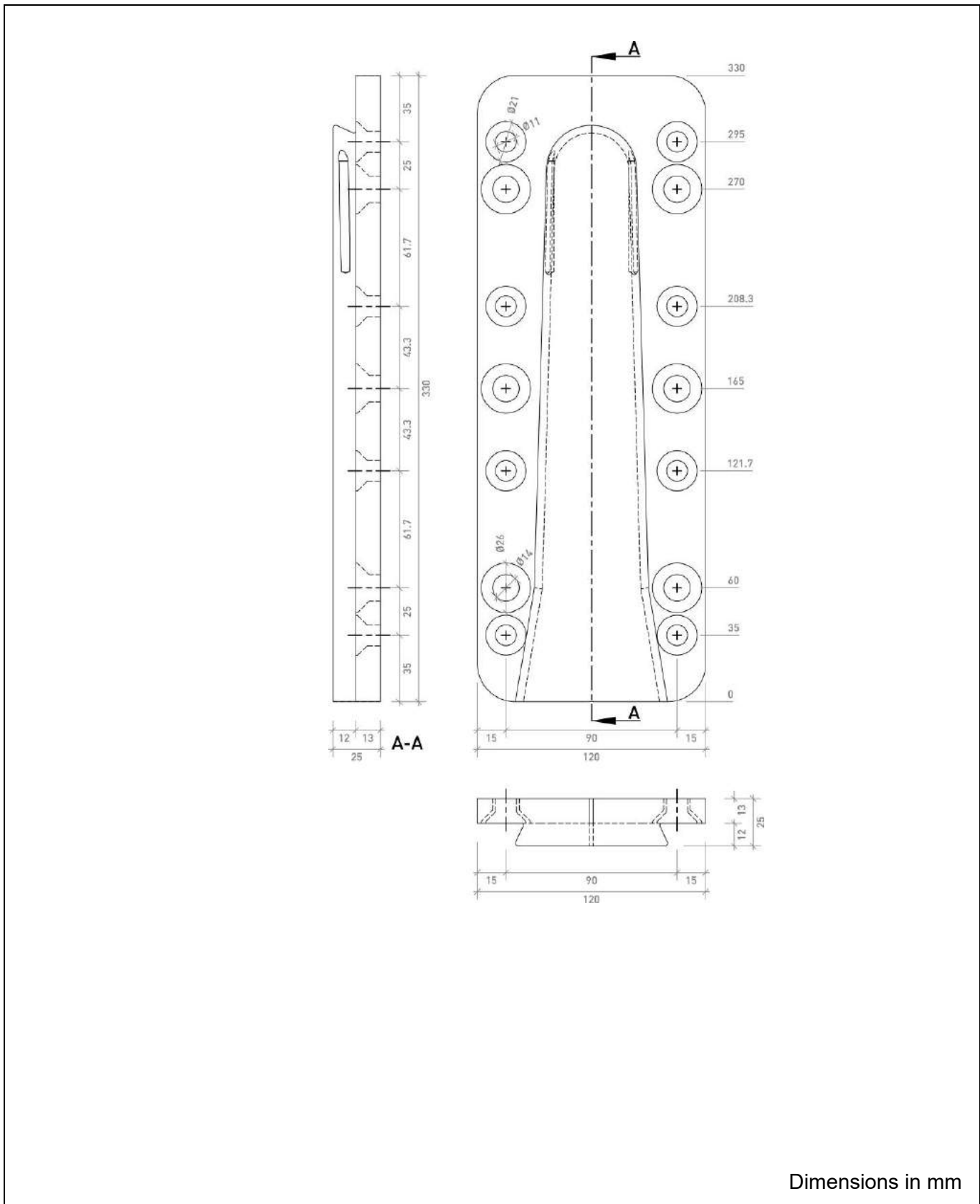

Dimensions in mm

Sherpa – XL CS	Annex 2 of European Technical Assessment ETA-12/0067 of 04.06.2018
Product details definitions: <u>Type XL 80 CS 29/120/330</u> Mounting: <u>main beam or column</u>	

electronic copy electronic copy electronic copy electronic copy electronic copy electronic copy electronic copy electronic copy electronic copy electronic copy

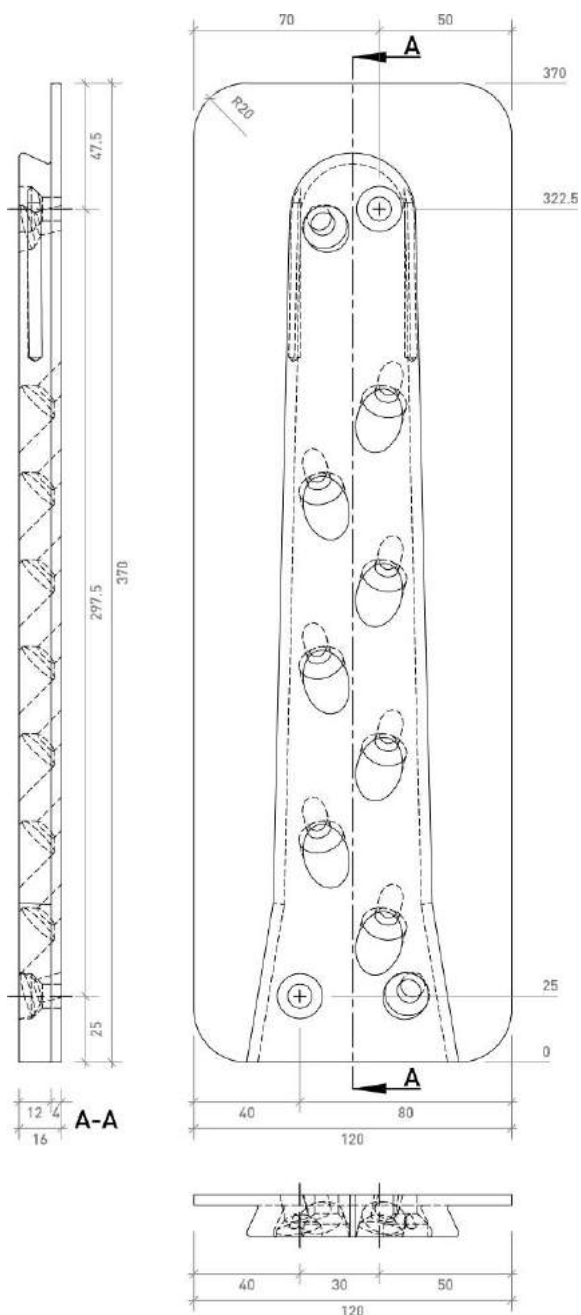

Dimensions in mm

Sherpa – XL

Product details definitions: Type XL 100 20/120/370
 Mounting: main beam or column

Annex 2

of European Technical Assessment
 ETA-12/0067 of 04.06.2018

electronic copy electronic copy electronic copy electronic copy electronic copy electronic copy electronic copy electronic copy electronic copy electronic copy

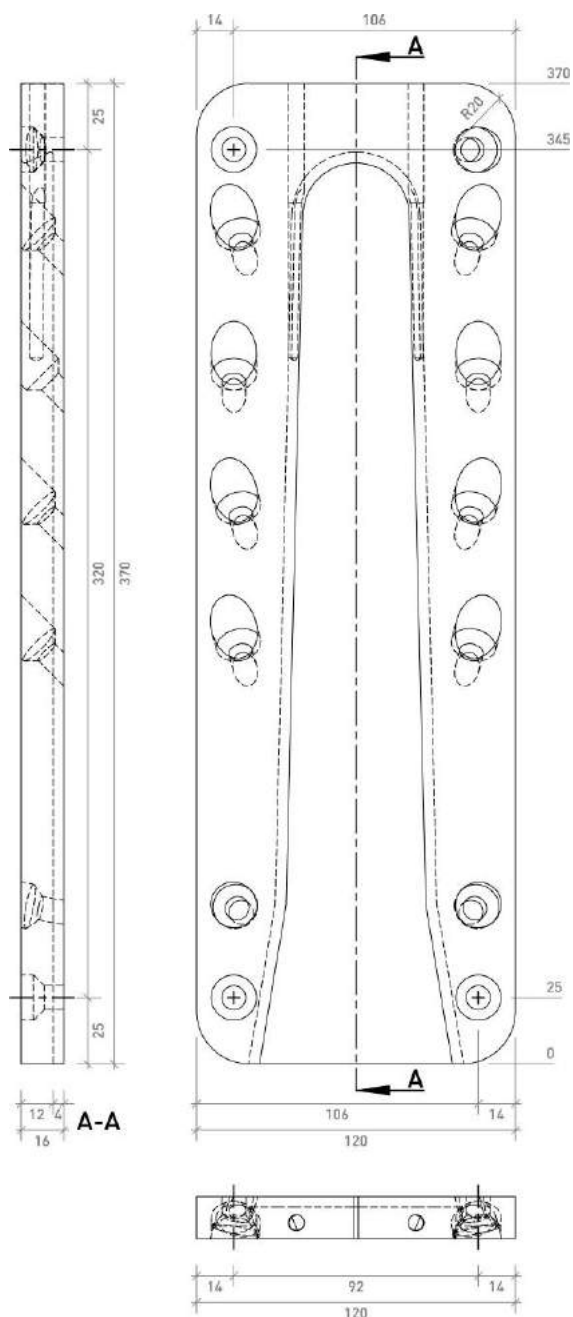

Dimensions in mm

Sherpa – XL

Product details definitions: Type XL 100 20/120/370
 Mounting: secondary beam

Annex 2

of European Technical Assessment
 ETA-12/0067 of 04.06.2018

electronic copy electronic copy electronic copy electronic copy electronic copy electronic copy electronic copy electronic copy electronic copy electronic copy

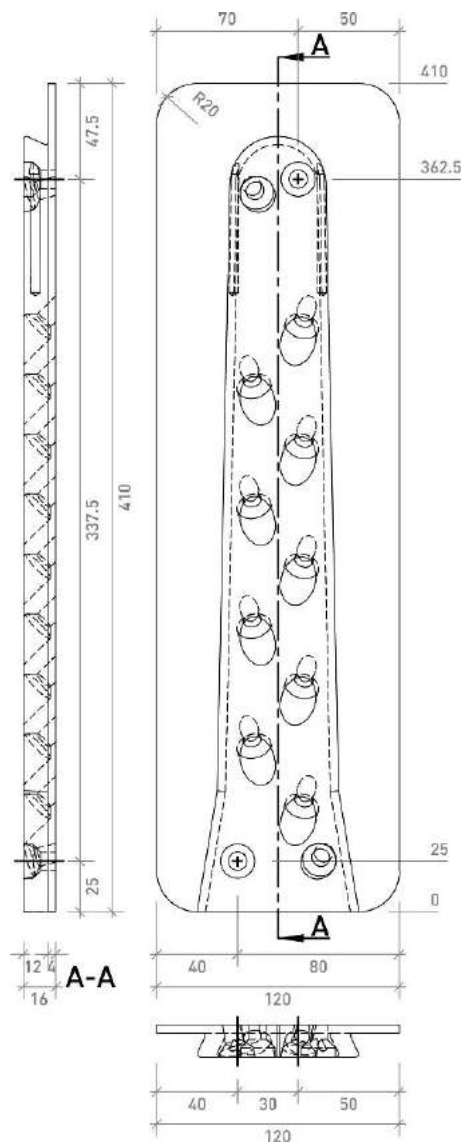

Dimensions in mm

Sherpa – XL	Annex 2 of European Technical Assessment ETA-12/0067 of 04.06.2018
Product details definitions: <u>Type XL 120 20/120/410</u> Mounting: <u>main beam or column</u>	

electronic copy electronic copy electronic copy electronic copy electronic copy electronic copy electronic copy electronic copy electronic copy electronic copy

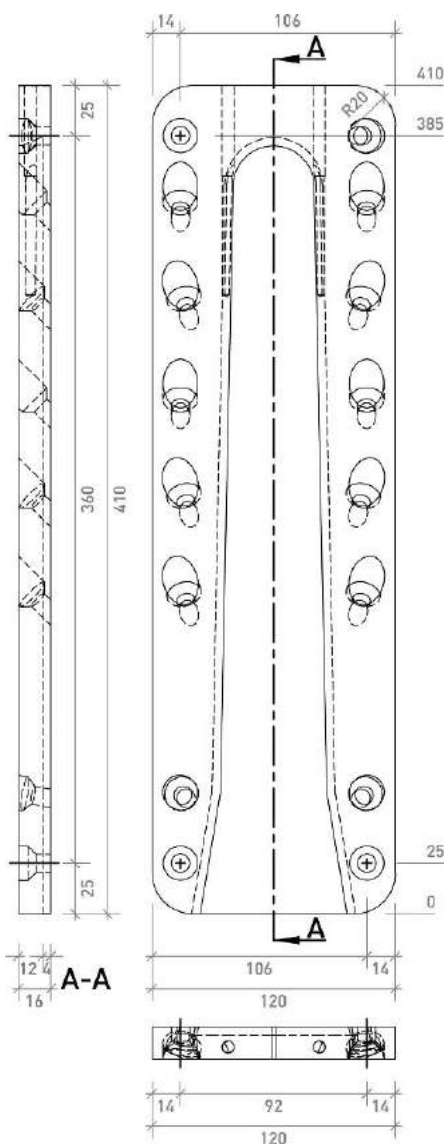

Dimensions in mm

Sherpa – XL

Product details definitions: Type XL 120 20/120/410
 Mounting: secondary beam

Annex 2

of European Technical Assessment
 ETA-12/0067 of 04.06.2018

electronic copy electronic copy electronic copy electronic copy electronic copy electronic copy electronic copy electronic copy electronic copy electronic copy

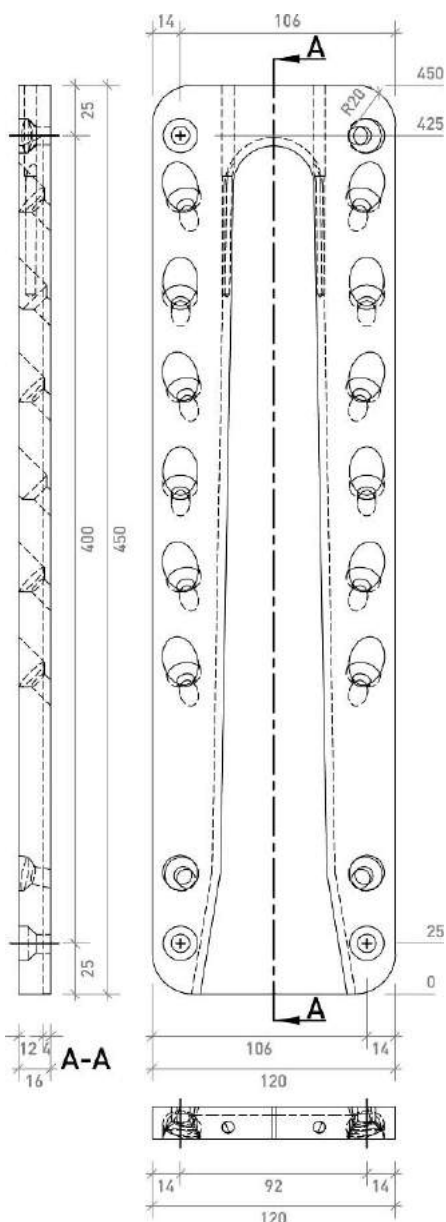

Dimensions in mm

Sherpa – XL

Product details definitions: Type XL 140 20/120/450
 Mounting: secondary beam

Annex 2

of European Technical Assessment
 ETA-12/0067 of 04.06.2018

electronic copy electronic copy electronic copy electronic copy electronic copy electronic copy electronic copy electronic copy electronic copy electronic copy

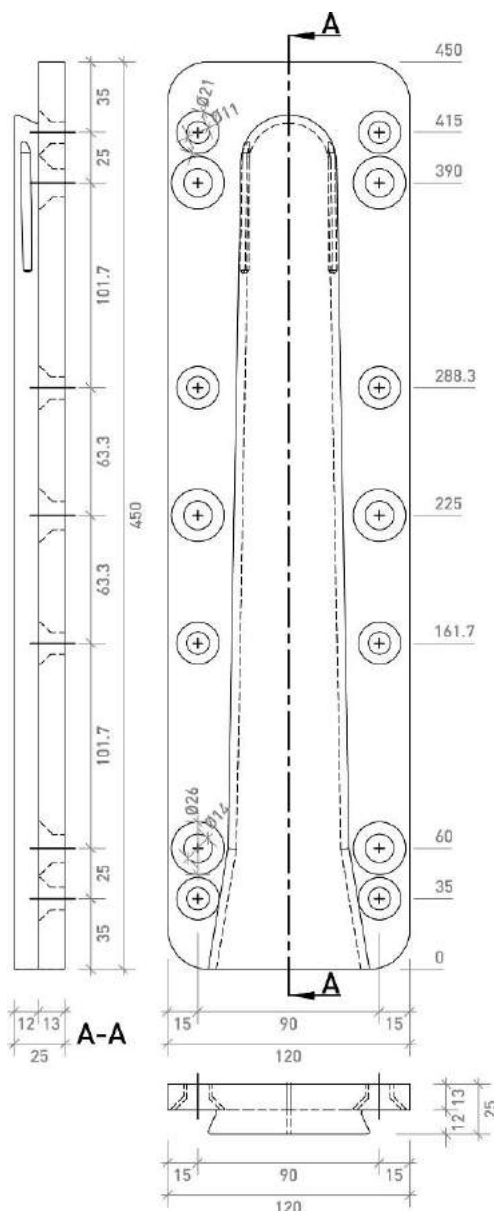

Dimensions in mm

Sherpa – XL CS	Annex 2 of European Technical Assessment ETA-12/0067 of 04.06.2018
Product details definitions: <u>Type XL 140 CS 29/120/450</u> Mounting: <u>main beam or column</u>	

electronic copy electronic copy electronic copy electronic copy electronic copy electronic copy electronic copy electronic copy electronic copy electronic copy

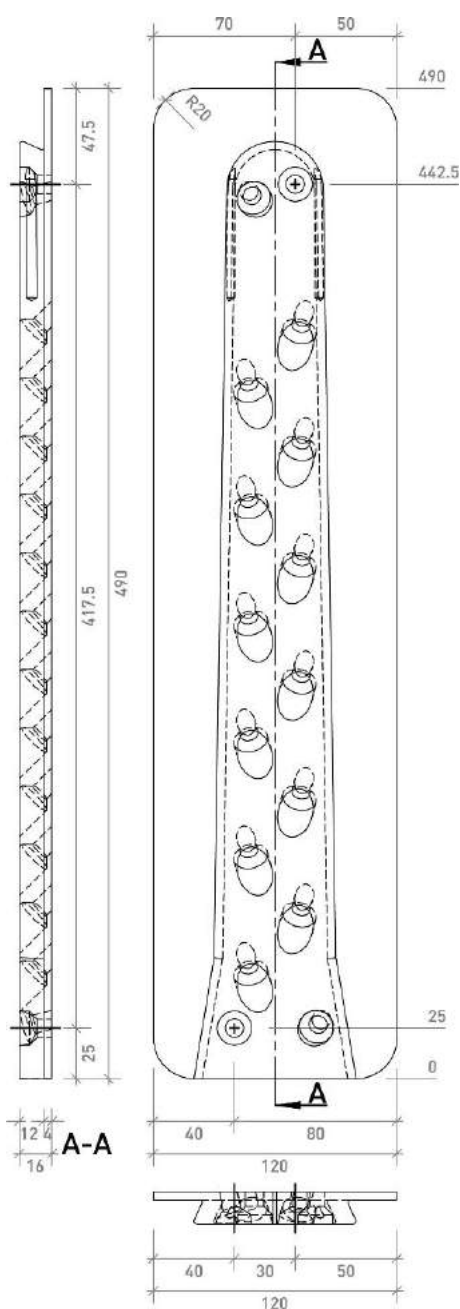

Dimensions in mm

Sherpa – XL

Product details definitions: Type XL 170 20/120/490
 Mounting: main beam or column

Annex 2

of European Technical Assessment
 ETA-12/0067 of 04.06.2018

electronic copy electronic copy electronic copy electronic copy electronic copy electronic copy electronic copy electronic copy electronic copy electronic copy

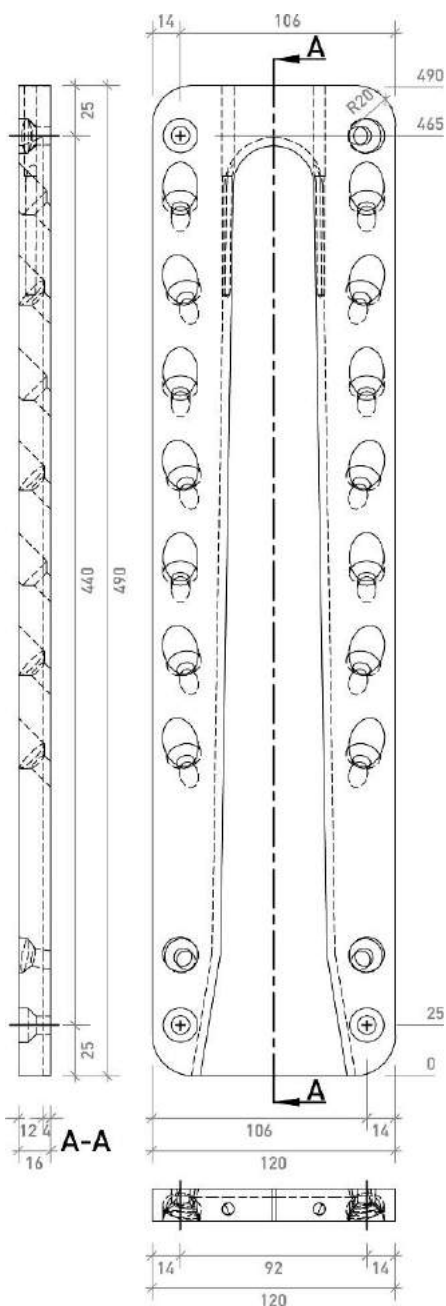

Dimensions in mm

Sherpa – XL

Product details definitions: Type XL 170 20/120/490
 Mounting: secondary beam

Annex 2

of European Technical Assessment
 ETA-12/0067 of 04.06.2018

electronic copy electronic copy electronic copy electronic copy electronic copy electronic copy electronic copy electronic copy electronic copy electronic copy

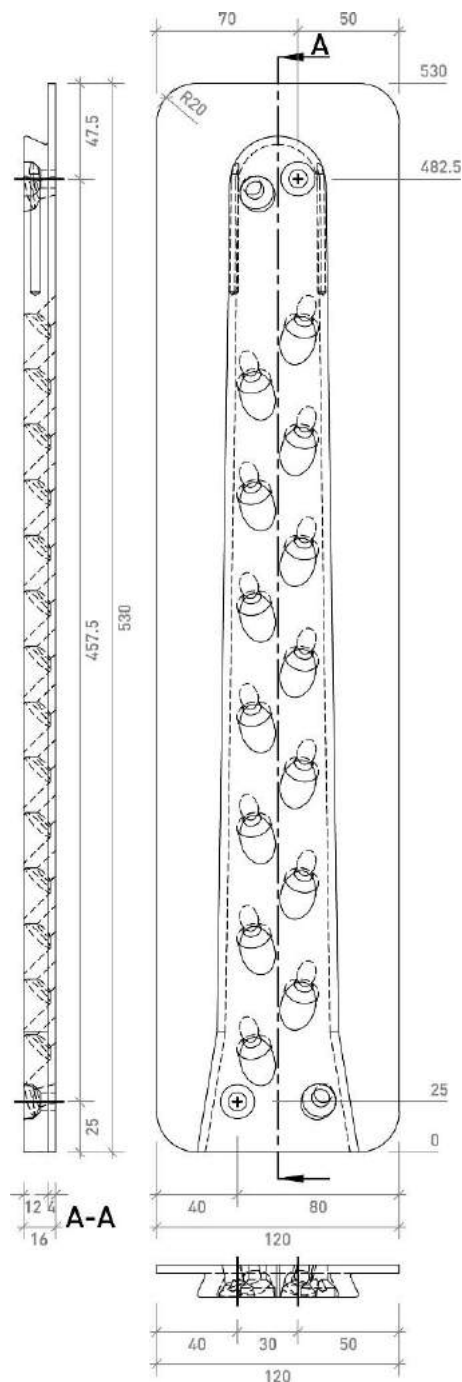

Dimensions in mm

Sherpa – XL

Product details definitions: Type XL 190 20/120/530
 Mounting: main beam or column

Annex 2

of European Technical Assessment
 ETA-12/0067 of 04.06.2018

electronic copy electronic copy electronic copy electronic copy electronic copy electronic copy electronic copy electronic copy electronic copy electronic copy

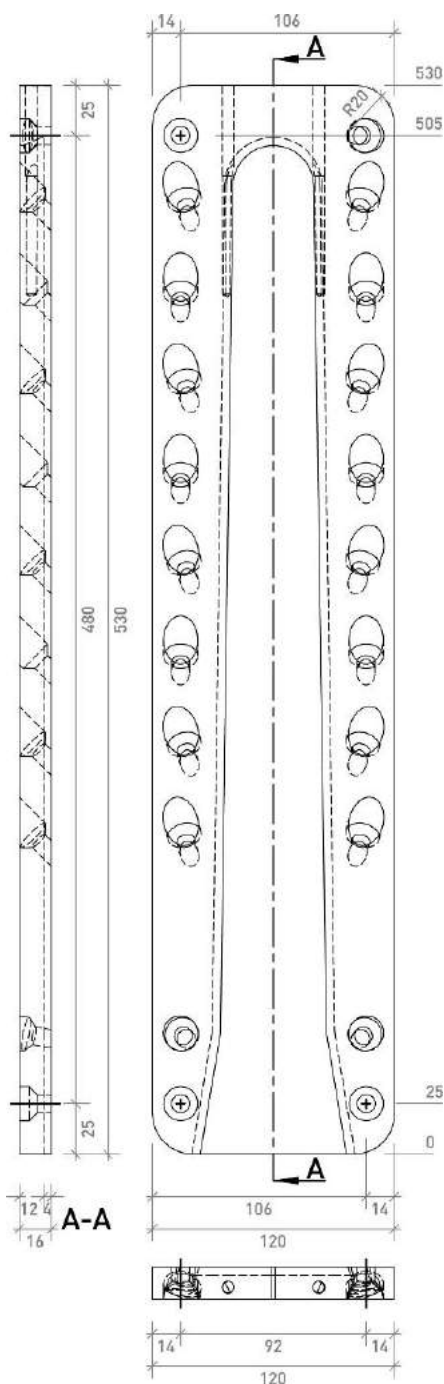

Dimensions in mm

Sherpa – XL

Product details definitions: Type XL 190 20/120/530
 Mounting: secondary beam

Annex 2

of European Technical Assessment
 ETA-12/0067 of 04.06.2018

electronic copy electronic copy electronic copy electronic copy electronic copy electronic copy electronic copy electronic copy electronic copy electronic copy

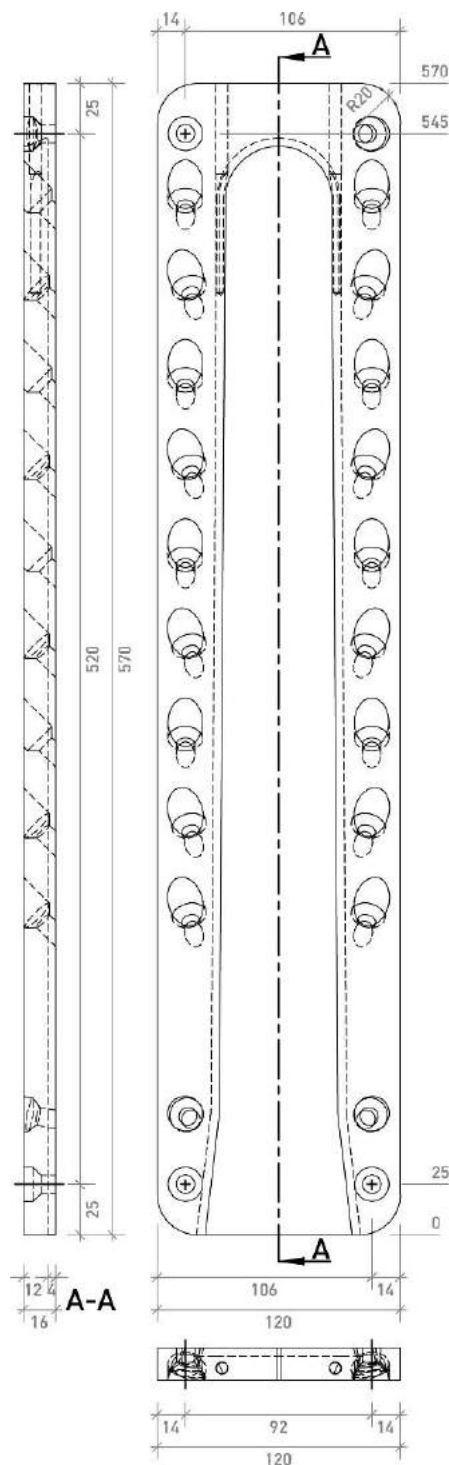

Dimensions in mm

Sherpa – XL

Product details definitions: Type XL 220 20/120/570
 Mounting: secondary beam

Annex 2

of European Technical Assessment
 ETA-12/0067 of 04.06.2018

electronic copy electronic copy electronic copy electronic copy electronic copy electronic copy electronic copy electronic copy electronic copy electronic copy

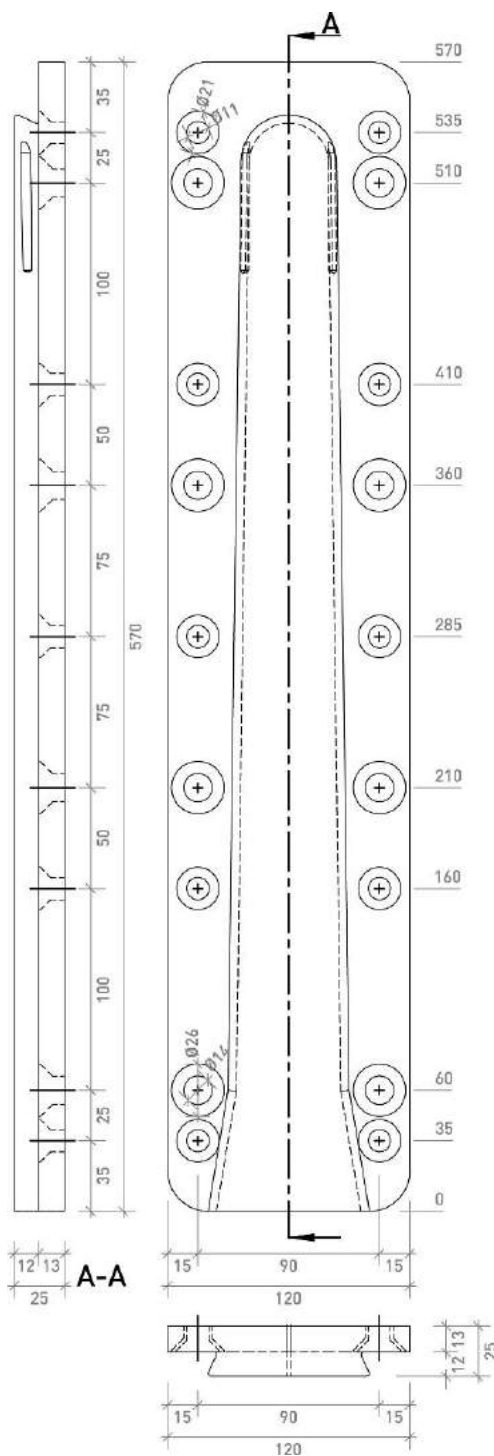

Dimensions in mm

Sherpa – XL CS	Annex 2 of European Technical Assessment ETA-12/0067 of 04.06.2018
Product details definitions: <u>Type XL 220 CS 29/120/570</u> Mounting: <u>main beam or column</u>	

electronic copy electronic copy electronic copy electronic copy electronic copy electronic copy electronic copy electronic copy electronic copy electronic copy

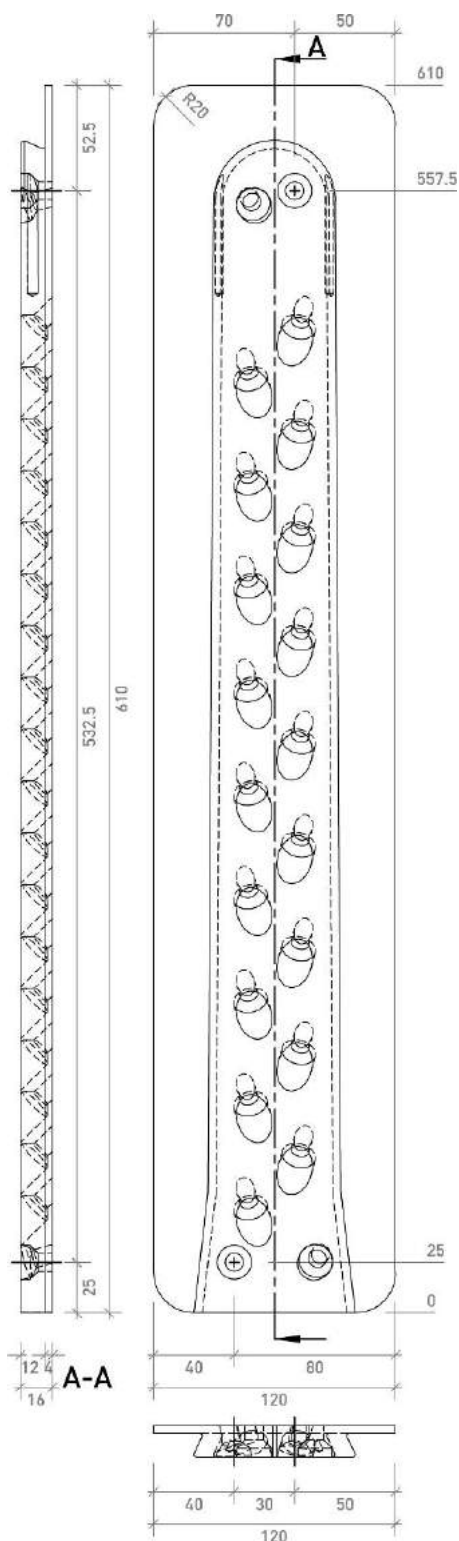

Dimensions in mm

Sherpa – XL

Product details definitions: Type XL 250 20/120/610
 Mounting: main beam or column

Annex 2

of European Technical Assessment
 ETA-12/0067 of 04.06.2018

electronic copy

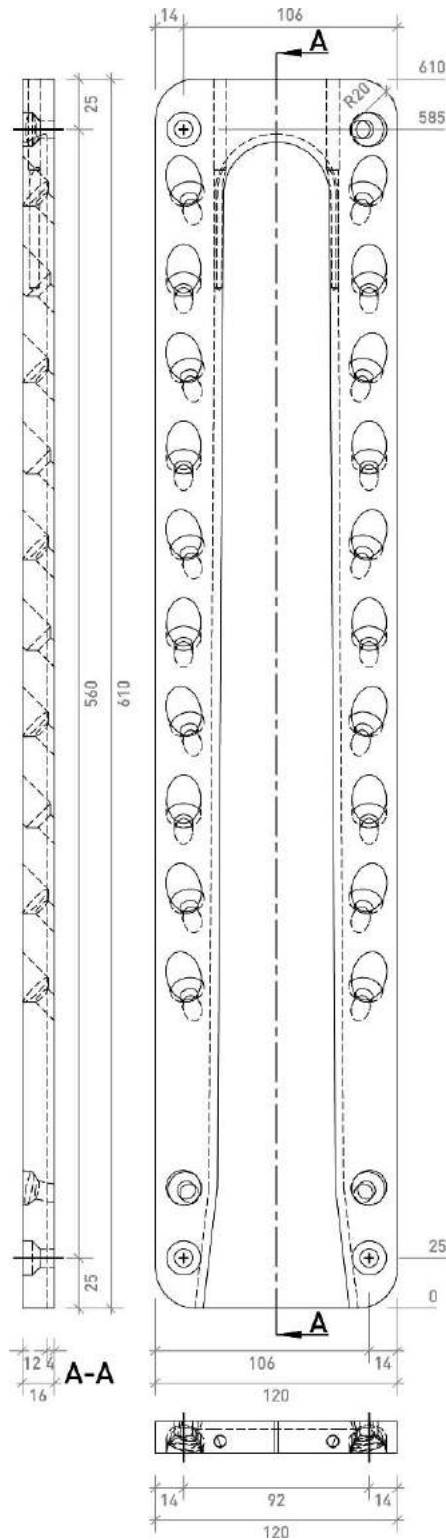

Dimensions in mm

Sherpa – XL

Product details definitions: Type XL 250 20/120/610
 Mounting: secondary beam

Annex 2

of European Technical Assessment
 ETA-12/0067 of 04.06.2018

electronic copy electronic copy electronic copy electronic copy electronic copy electronic copy electronic copy electronic copy electronic copy electronic copy

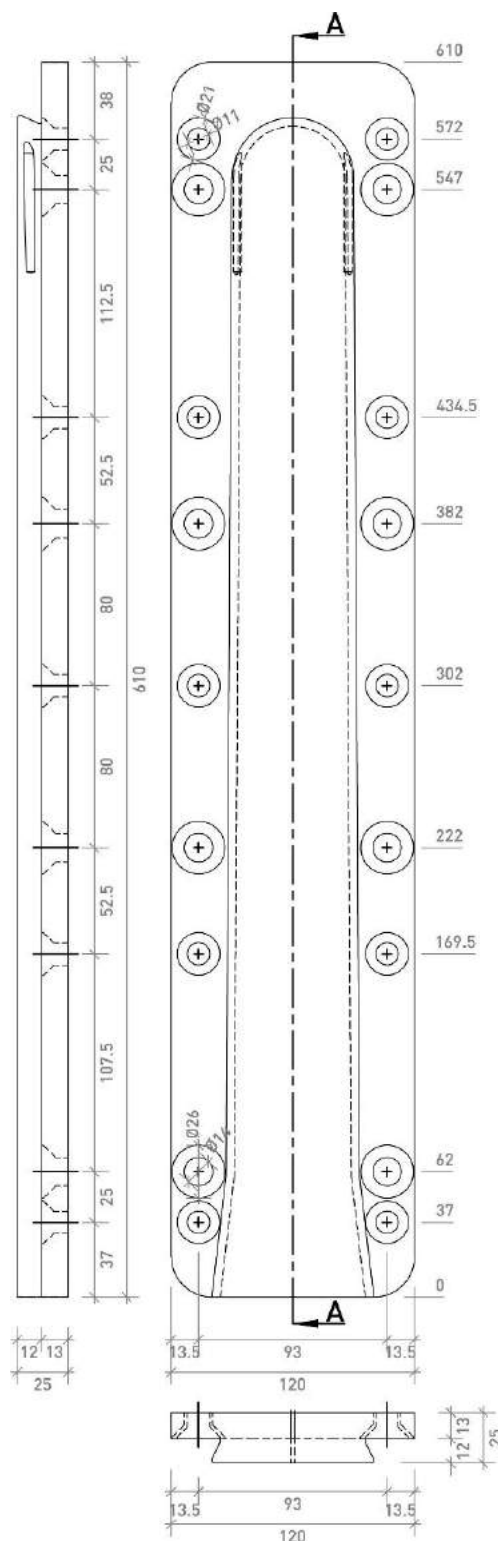

Dimensions in mm

Sherpa – XL CS	Annex 2 of European Technical Assessment ETA-12/0067 of 04.06.2018
Product details definitions: <u>Type XL 250 CS 29/120/610</u> Mounting: <u>main beam or column</u>	

electronic copy electronic copy electronic copy electronic copy electronic copy electronic copy electronic copy electronic copy electronic copy electronic copy

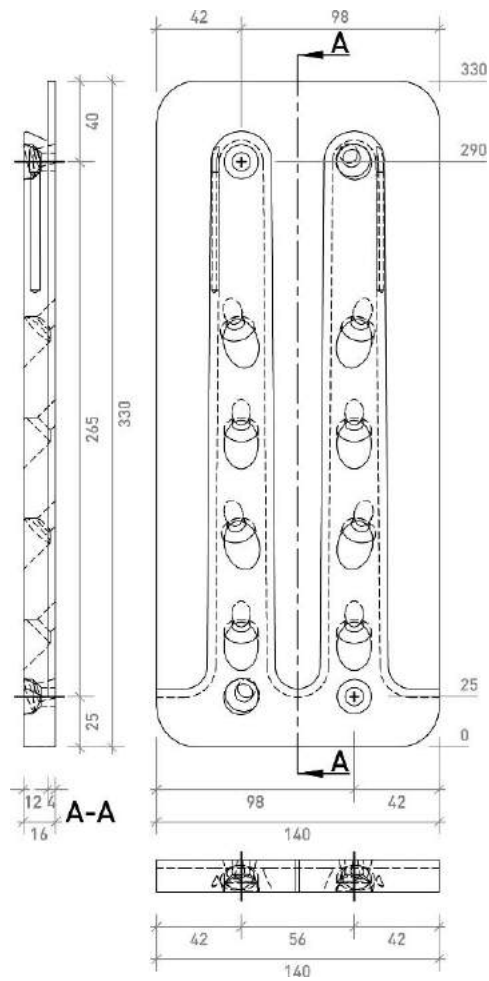

Dimensions in mm

Sherpa – XXL

Product details definitions: Type XXL 120 20/140/330

Mounting: main beam or column

Annex 2

of European Technical Assessment
 ETA-12/0067 of 04.06.2018

electronic copy electronic copy electronic copy electronic copy electronic copy electronic copy electronic copy electronic copy electronic copy electronic copy

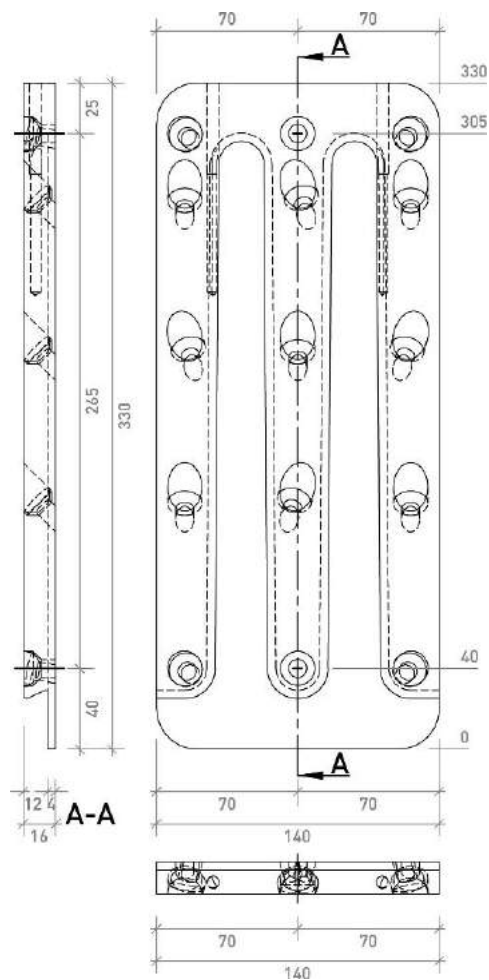

Dimensions in mm

Sherpa – XXL

Product details definitions: Type XXL 120 20/140/330

Mounting: secondary beam

Annex 2

of European Technical Assessment
 ETA-12/0067 of 04.06.2018

electronic copy electronic copy electronic copy electronic copy electronic copy electronic copy electronic copy electronic copy electronic copy electronic copy

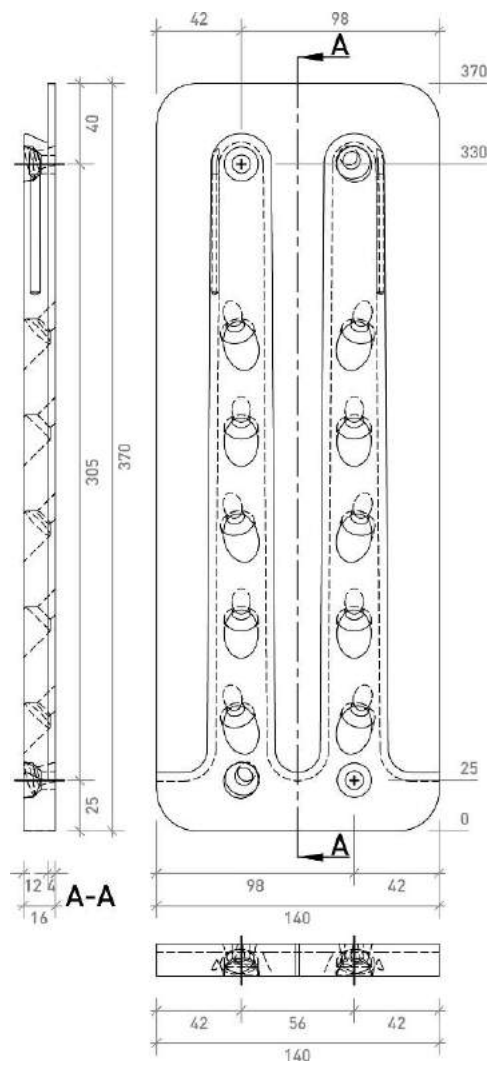

Dimensions in mm

Sherpa – XXL

Product details definitions: Type XXL 140 20/140/370
 Mounting: main beam or column

Annex 2

of European Technical Assessment
 ETA-12/0067 of 04.06.2018

electronic copy electronic copy electronic copy electronic copy electronic copy electronic copy electronic copy electronic copy electronic copy electronic copy

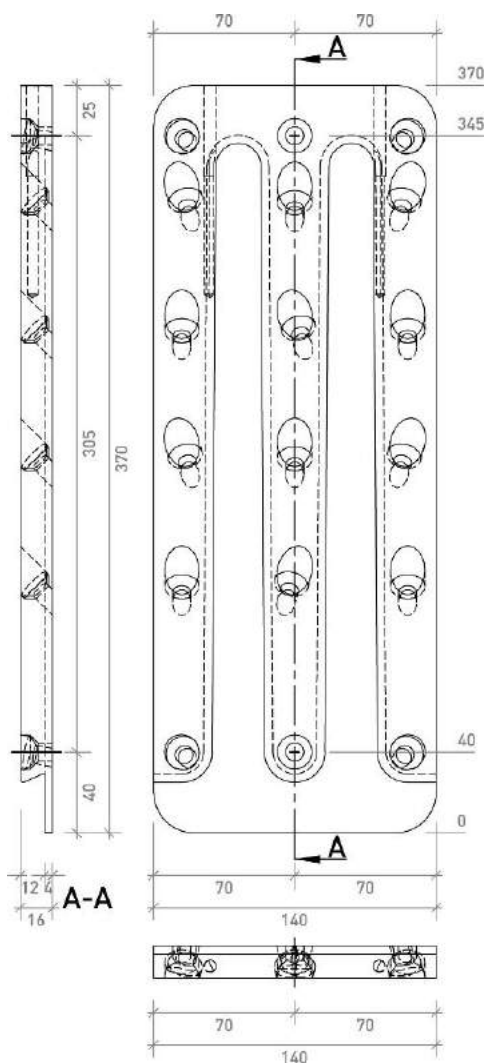

Dimensions in mm

Sherpa – XXL

Product details definitions: Type XXL 140 20/140/370

Mounting: secondary beam

Annex 2

of European Technical Assessment
 ETA-12/0067 of 04.06.2018

electronic copy electronic copy electronic copy electronic copy electronic copy electronic copy electronic copy electronic copy electronic copy electronic copy

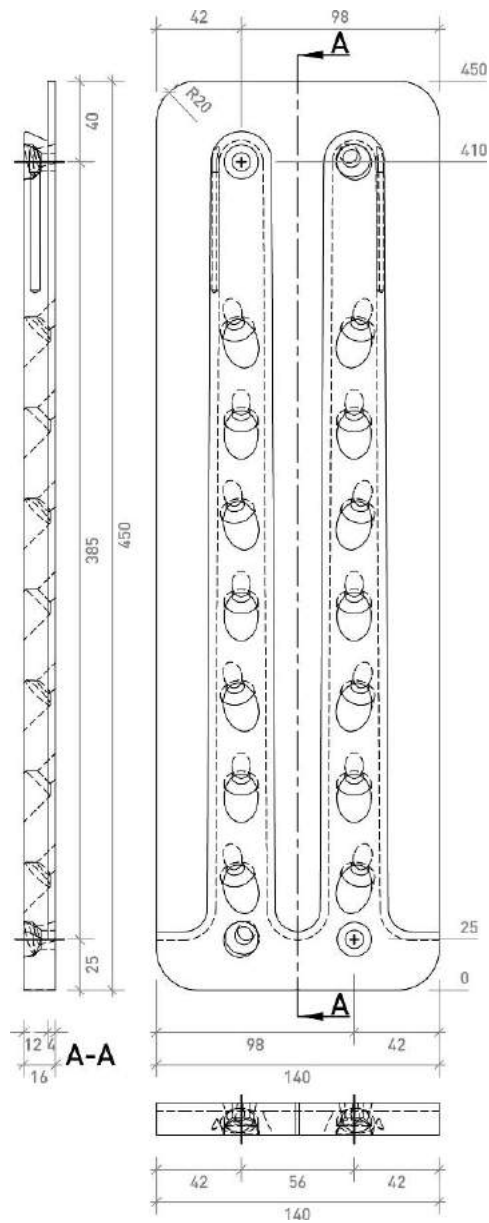

Dimensions in mm

Sherpa – XXL

Product details definitions: Type XXL 190 20/140/450

Mounting: main beam or column

Annex 2

of European Technical Assessment
 ETA-12/0067 of 04.06.2018

electronic copy electronic copy electronic copy electronic copy electronic copy electronic copy electronic copy electronic copy electronic copy electronic copy

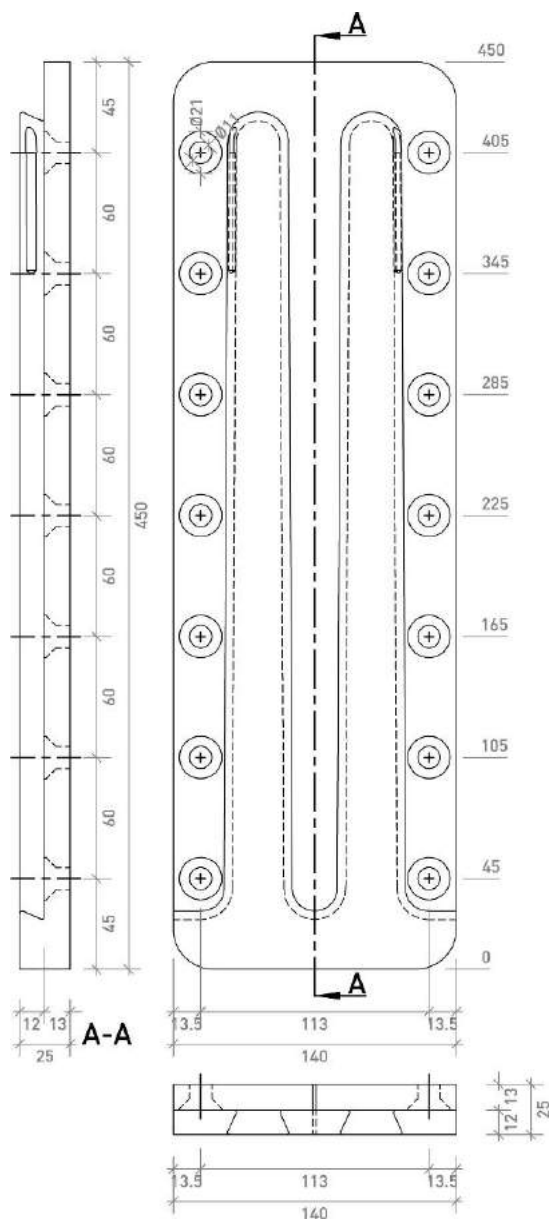

Dimensions in mm

Sherpa – XXL CS	Annex 2 of European Technical Assessment ETA-12/0067 of 04.06.2018
Product details definitions: <u>Type XXL CS 190 29/140/450</u> Mounting: <u>main beam or column</u>	

electronic copy electronic copy electronic copy electronic copy electronic copy electronic copy electronic copy electronic copy electronic copy electronic copy

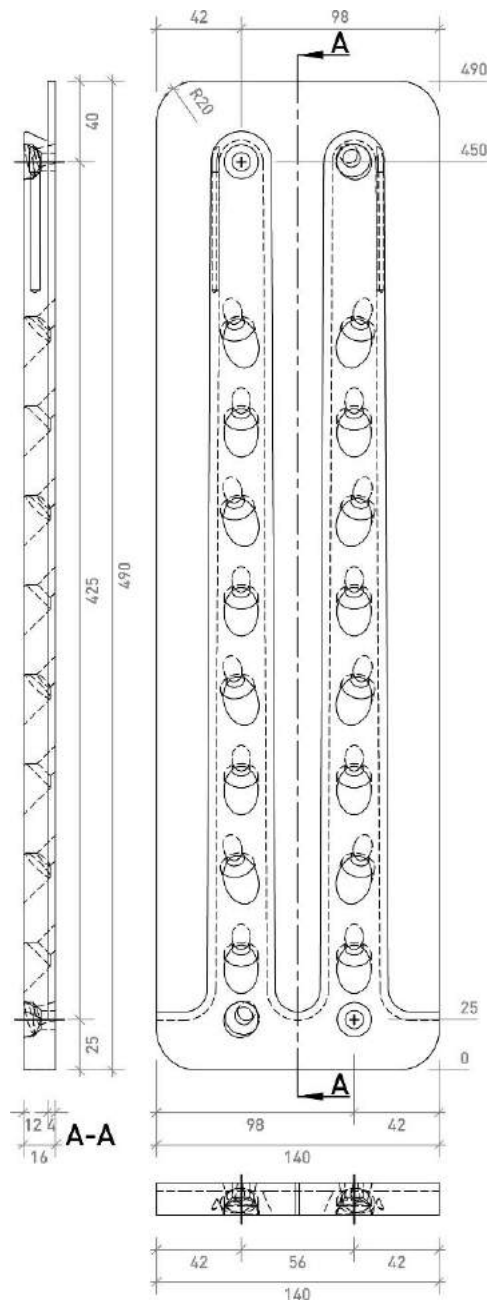

Dimensions in mm

Sherpa – XXL

Product details definitions: Type XXL 220 20/140/490

Mounting: main beam or column

Annex 2

of European Technical Assessment
 ETA-12/0067 of 04.06.2018

electronic copy electronic copy electronic copy electronic copy electronic copy electronic copy electronic copy electronic copy electronic copy electronic copy

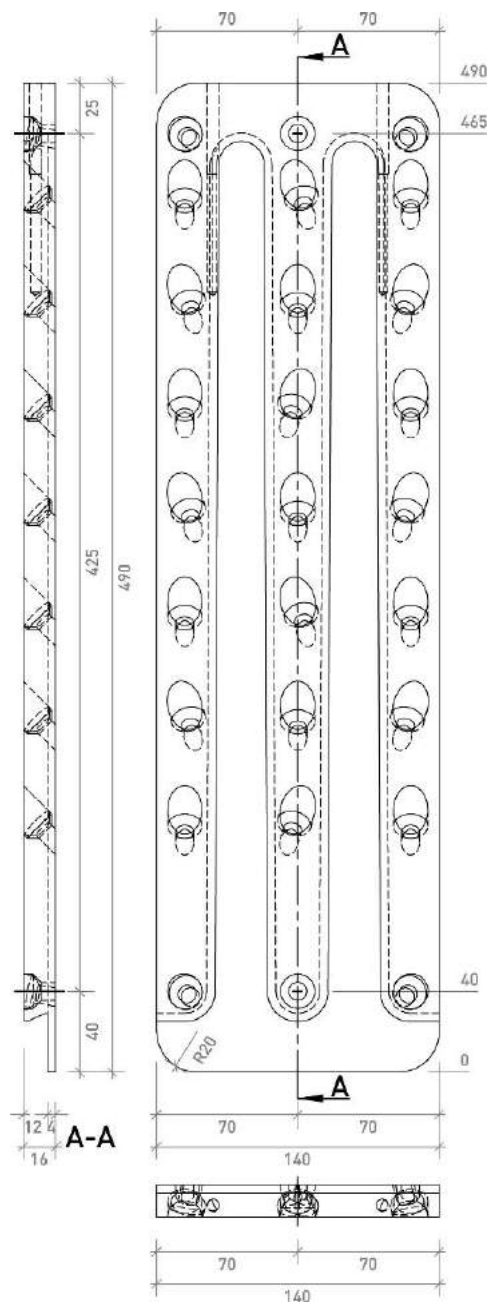

Dimensions in mm

Sherpa – XXL

Product details definitions: Type XXL 220 20/140/490

Mounting: secondary beam

Annex 2

of European Technical Assessment
 ETA-12/0067 of 04.06.2018

electronic copy electronic copy electronic copy electronic copy electronic copy electronic copy electronic copy electronic copy electronic copy electronic copy

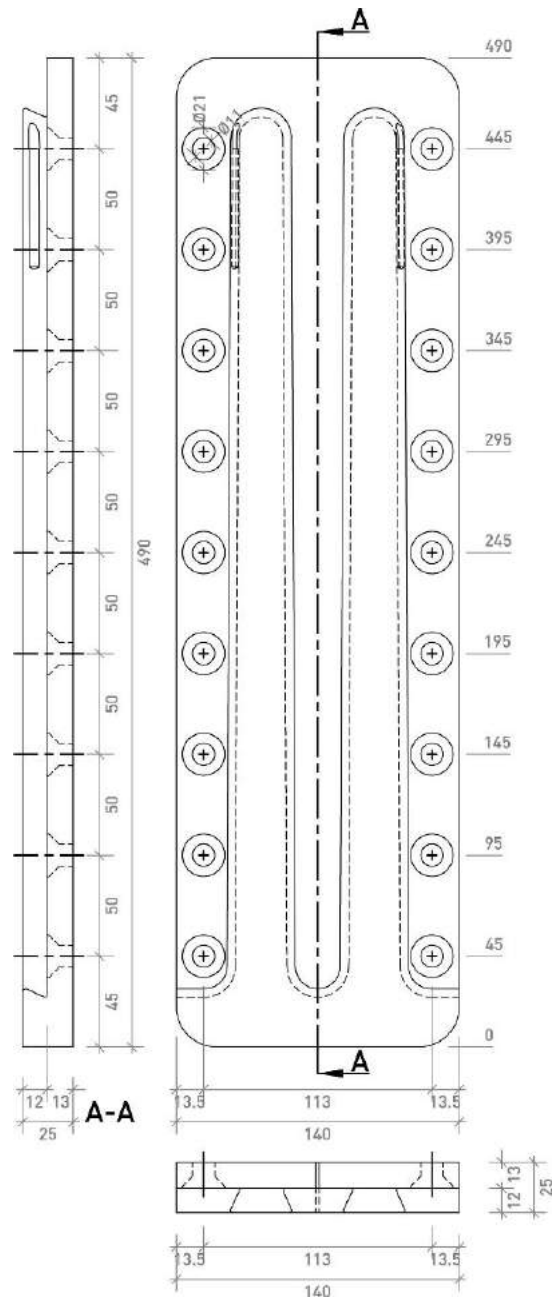

Dimensions in mm

Sherpa – XXL CS

Product details definitions: Type XXL 220 CS 29/140/490
 Mounting: main beam or column

Annex 2

of European Technical Assessment
 ETA-12/0067 of 04.06.2018

electronic copy electronic copy electronic copy electronic copy electronic copy electronic copy electronic copy electronic copy electronic copy electronic copy

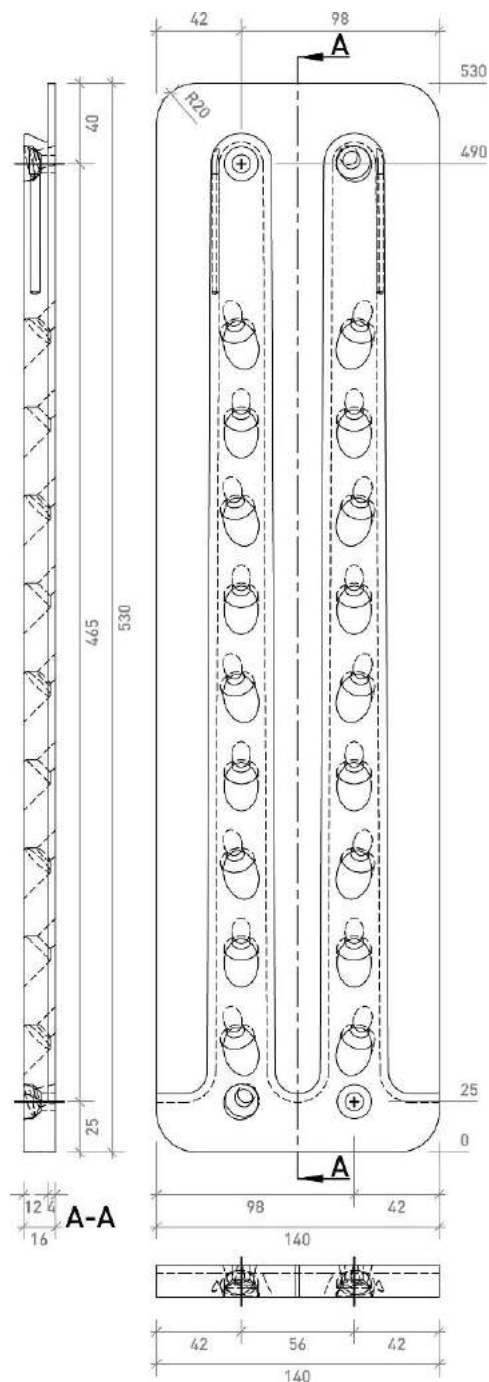

Dimensions in mm

Sherpa – XXL

Product details definitions: Type XXL 250 20/140/530

Mounting: main beam or column

Annex 2

of European Technical Assessment
 ETA-12/0067 of 04.06.2018

electronic copy electronic copy electronic copy electronic copy electronic copy electronic copy electronic copy electronic copy electronic copy electronic copy

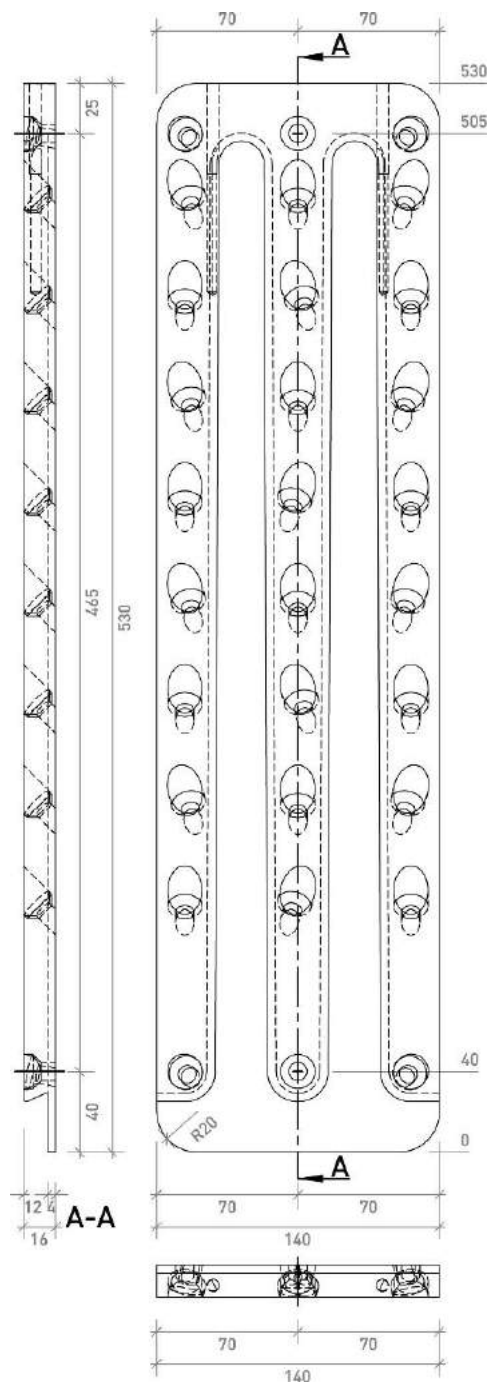

Dimensions in mm

Sherpa – XXL

Product details definitions: Type XXL 250 20/140/530

Mounting: secondary beam

Annex 2

of European Technical Assessment
 ETA-12/0067 of 04.06.2018

electronic copy electronic copy electronic copy electronic copy electronic copy electronic copy electronic copy electronic copy electronic copy electronic copy

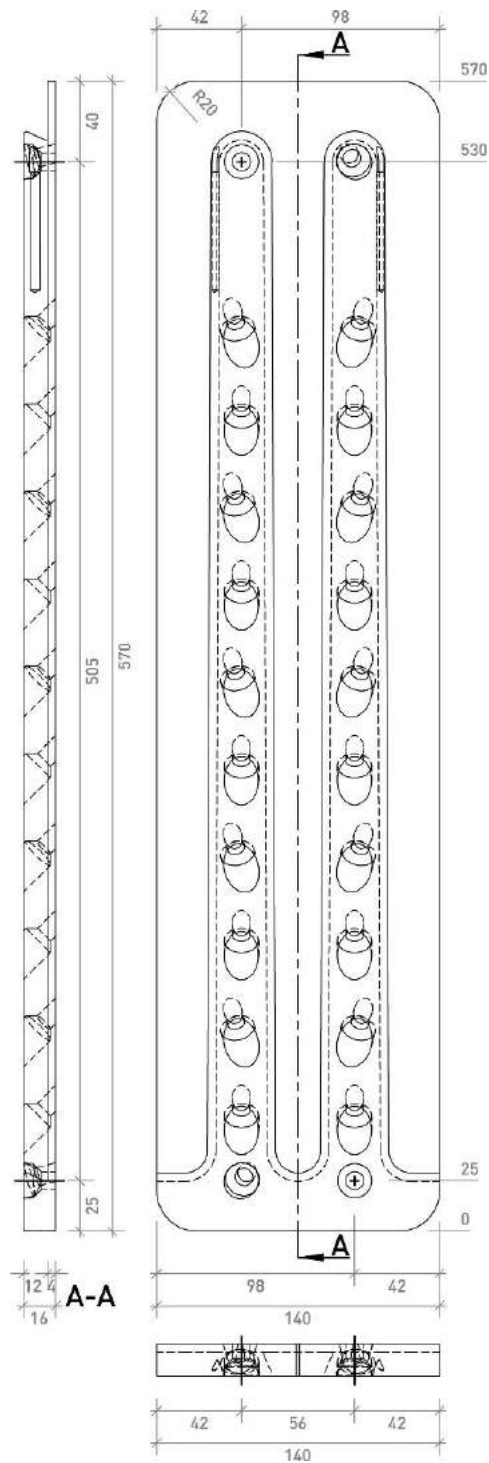

Dimensions in mm

Sherpa – XXL

Product details definitions: Type XXL 280 20/140/570

Mounting: main beam or column

Annex 2

of European Technical Assessment
 ETA-12/0067 of 04.06.2018

electronic copy electronic copy electronic copy electronic copy electronic copy electronic copy electronic copy electronic copy electronic copy electronic copy

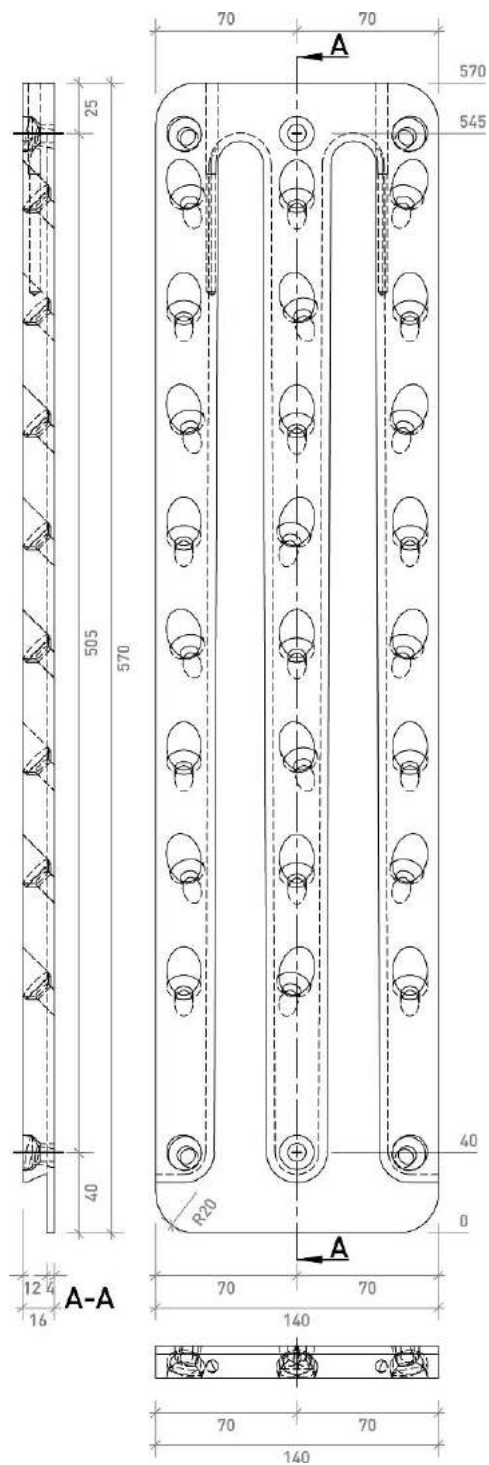

Dimensions in mm

Sherpa – XXL

Product details definitions: Type XXL 280 20/140/570

Mounting: secondary beam

Annex 2

of European Technical Assessment
 ETA-12/0067 of 04.06.2018

electronic copy electronic copy electronic copy electronic copy electronic copy electronic copy electronic copy electronic copy electronic copy electronic copy

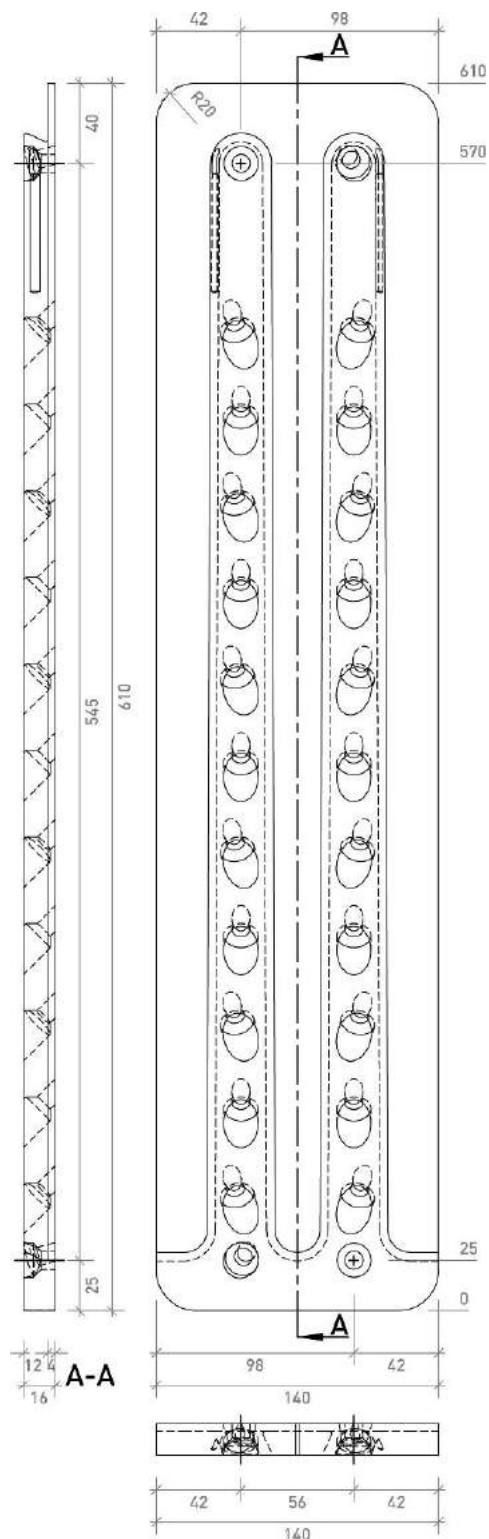

Dimensions in mm

Sherpa – XXL

Product details definitions: Type XXL 300 20/140/610
 Mounting: main beam or column

Annex 2

of European Technical Assessment
 ETA-12/0067 of 04.06.2018

electronic copy electronic copy electronic copy electronic copy electronic copy electronic copy electronic copy electronic copy electronic copy electronic copy

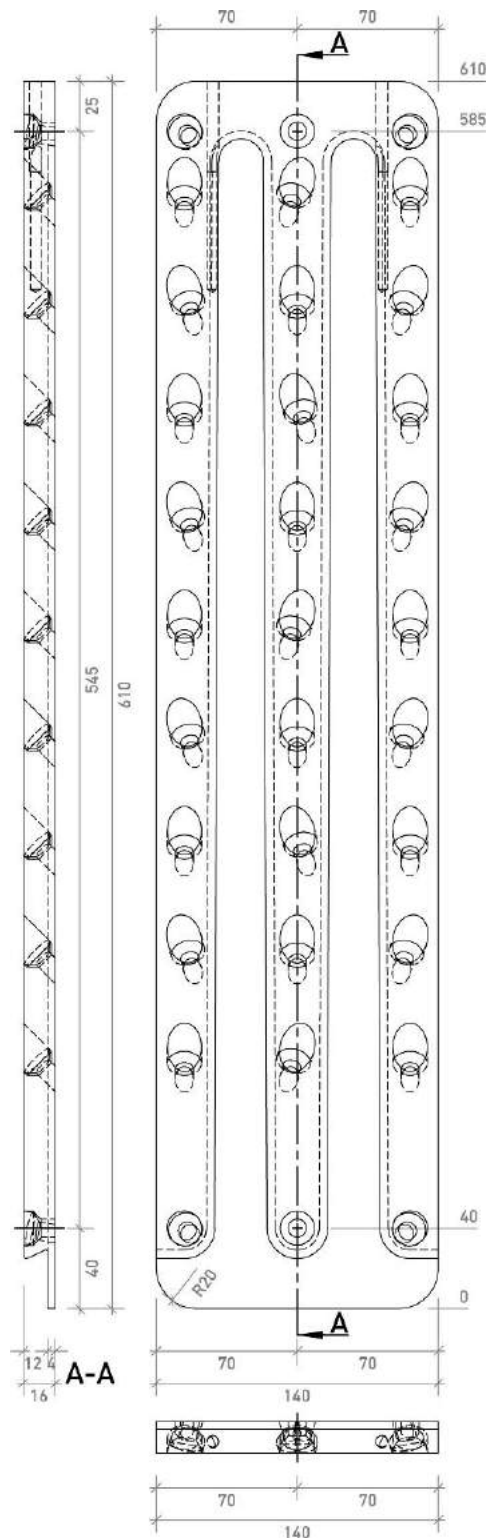

Dimensions in mm

Sherpa – XXL

Product details definitions: Type XXL 300 20/140/610

Mounting: secondary beam

Annex 2

of European Technical Assessment
 ETA-12/0067 of 04.06.2018

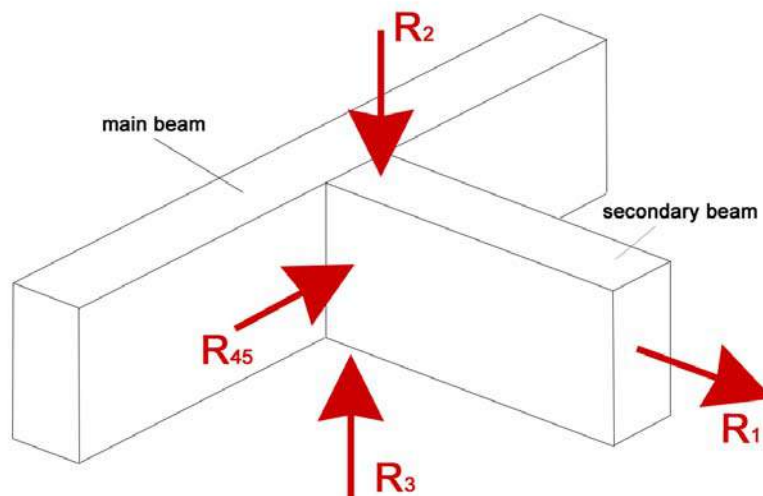

Wooden structural components

Solid timber of softwood of strength class C24 or better according to EN 338 and EN 14081-1,
 Glued laminated timber and glued solid timber of softwood of strength class GL24h or better according to EN 14080 or glued laminated timber of hardwood according to European Technical Assessments or national provisions that apply on the installation site,

Laminated veneer lumber LVL according to EN 14374 or according to European Technical Assessments or national provisions that apply on the installation site,

Cross laminated timber according to European Technical Assessments or national standards and regulations in force at the place of use.

Strand lumber (e.g. Laminated Strand Lumber - Intrallam, Parallell Strand Lumber - Parallam) according to European Technical Assessments or national standards and regulations in force at the place of use.

The main beam may also be of concrete or steel.

Forces and their directions

- R₂ Force acting in direction of insertion. Connection of main beam or column and secondary beam. The members shall be prevented from rotation or the eccentric loading, Annex 5, has to be considered.
- R₄₅ Force acting perpendicular to direction of insertion. Connection of main beam or column and secondary beam. The members shall be prevented from rotation or the eccentric loading, Annex 5, has to be considered.
- R₁ Force acting in direction of secondary beam. Connection of main beam or column and secondary beam. In case of rotating members, Annex 5, has to be considered.
- R₃ Force acting against direction of insertion. Connection of main beam or column and secondary beam. The members shall be prevented from rotation or the eccentric loading, Annex 5, has to be considered.

Sherpa – XS, S, M, L ,XL and XXL	Annex 4
Definition of forces and their directions	of European Technical Assessment ETA-12/0067 of 04.06.2018

electronic copy

Product	Dimensions H/B/L	Characteristic load bearing capacity					
		$R_{2,k,SW}^{1)}$	$R_{2,k,GLT}^{2)}$	$R_{45,k,SW}^{3)}$	$R_{45,k,GLT}^{3)}$	$R_{1,k,SW}$	$R_{1,k,GLT}$
	mm	kN	kN	kN	kN	kN	kN
Type XS 5	12/30/50	5.1	6.3	3.2	3.3	3.6	4.4
Type XS 10	12/30/70	9.6	11.8	5.0	5.2	6.7	8.3
Type XS 15	12/30/90	11.7	14.4	5.9	6.2	8.2	10.1
Type XS 20	12/30/110	15.9	19.5	6.8	7.1	11.2	13.7
Type S 5	12/40/50	5.1	6.3	3.2	3.3	3.6	4.4
Type S 10	12/40/70	9.6	11.8	5.0	5.2	6.7	8.3
Type S 15	12/40/90	11.7	14.4	5.9	6.2	8.2	10.1
Type S 20	12/40/110	15.9	19.5	6.8	7.1	11.2	13.7

¹⁾ value for solid wood; splitting takes place in the middle of the connector for type XS and in the next to last row of screws for Type S; the parameter h_e appearing in EN 1995-1-1, (8.4), is the distance from splitting-height to the loaded side of the wooden beam.

²⁾ value for glued laminated timber; splitting takes place in the middle of the connector for type XS and in the last row of screws for Type S; the parameter h_e appearing in EN 1995-1-1, (8.4), is the distance from splitting-height to the loaded side of the wooden beam.

³⁾ splitting takes place in the upper end of the connector for Type XS and S; the parameter h_e appearing in EN 1995-1-1, (8.4), is the distance from splitting-height to the loaded side of the wooden beam.

Product	Characteristic load bearing capacity				
	$R_{tor,k,SW}$	$R_{tor,k,GLT}$	e_{grenz}	e_2	e_{45}
	kNmm	kNmm	mm	mm	mm
Type XS 5	59	61	0	36.1	33.5
Type XS 10	117	122	8.3	18.9	21.3
Type XS 15	176	183	12.5	19.4	18.1
Type XS 20	246	256	16.3	19.6	15.7
Type S 5	66	69	0	36.1	44.2
Type S 10	128	134	8.3	18.9	28.2
Type S 15	187	195	12.5	19.4	23.9
Type S 20	258	268	16.3	19.6	20.7

Sherpa – XS and S

Characteristic load bearing capacities

Annex 5

of European Technical Assessment
ETA-12/0067 of 04.06.2018

Product	Dimensions	Characteristic load bearing capacity ⁴⁾					
	H/B/L	$R_{2,k,SW}^{1)}$	$R_{2,k,GLT}^{2) 5)}$	$R_{45,k,SW}^{3)}$	$R_{45,k,GLT}^{3)}$	$R_{1,k,SW}$	$R_{1,k,GLT}^{5)}$
	mm	kN	kN	kN	kN	kN	kN
Type M 15	14/60/90	12.1	14.9	8.1	8.4	8.5	10.5
Type M 20	14/60/110	19.2	23.6	9.6	10.0	13.5	16.6
Type M 25	14/60/130	22.7	27.8	11.2	11.7	15.9	19.5
Type M 30	14/60/150	26.0	32.0	12.8	13.3	18.3	22.4
Type M 40	14/60/170	32.6	40.1	14.3	14.9	22.9	28.1

- ¹⁾ value for solid wood; splitting takes place in the next to last row of screws for Type M; the parameter h_e appearing in EN 1995-1-1, (8.4), is the distance from splitting-height to the loaded side of the wooden beam.
- ²⁾ value for glued laminated timber; splitting takes place in the last row of screws for Type M; the parameter h_e appearing in EN 1995-1-1, (8.4), is the distance from splitting-height to the loaded side of the wooden beam.
- ³⁾ splitting takes place in the upper row of screws for Type M; the parameter h_e appearing in EN 1995-1-1, (8.4), is the distance from splitting-height to the loaded side of the wooden beam.
- ⁴⁾ Characteristic load bearing capacity for screw length $l = 65$ mm. The char. load bearing capacity can be multiplied by the screw length factor $n_s = 1.40$ for screw lengths $l = 85$ mm or by the screw length factor $n_s = 1.80$ for screw lengths $l = 105$ mm.
- ⁵⁾ Characteristic load bearing capacity of SHERPA special screws in hardwood can be multiplied by the hardwood factor $k_{LH} = 2.3$.

Product	Characteristic load bearing capacity ⁴⁾				
	$R_{tor,k,SW}$	$R_{tor,k,GLT}$	e_{grenz}	e_2	e_{45}
	kNmm	kNmm	mm	mm	mm
Type M 15	271	283	10	32.3	50.5
Type M 20	379	395	13.3	28.4	42.3
Type M 25	505	527	16.7	26.5	36.4
Type M 30	651	678	20	25.3	31.9
Type M 40	813	848	23.3	24.5	28.4

Sherpa – M

Characteristic load bearing capacities

Annex 5

of European Technical Assessment
ETA-12/0067 of 04.06.2018

Product	Dimensions	Characteristic load bearing capacity ⁴⁾					
	H/B/L	R _{2,k,SW} ¹⁾	R _{2,k,GLT} ^{2) 5)}	R _{45,k,SW} ³⁾	R _{45,k,GLT} ³⁾	R _{1,k,SW}	R _{1,k,GLT} ⁵⁾
	mm	kN	kN	kN	kN	kN	kN
Type L 30	18/80/150	29.4	36.1	14.7	15.3	20.7	25.4
Type L 40	18/80/170	36.0	44.2	17.5	18.2	25.3	31.0
Type L 50	18/80/210	42.4	52.0	20.4	21.2	29.8	36.5
Type L 60	18/80/250	54.9	67.4	23.2	24.2	38.5	47.3
Type L 80	18/80/290	67.1	82.4	26.0	27.1	47.1	57.9
Type L 100	18/80/330	79.1	97.1	28.9	30.1	55.5	68.2
Type L 120	18/80/370	90.8	111.6	31.7	33.1	63.8	78.3

1) value for solid wood; splitting takes place in the next to last row of screws for Type L; the parameter h_e appearing in EN 1995-1-1, (8.4), is the distance from splitting-height to the loaded side of the wooden beam.

2) value for glued laminated timber; splitting takes place in the last row of screws for Type L; the parameter h_e appearing in EN 1995-1-1, (8.4), is the distance from splitting-height to the loaded side of the wooden beam.

3) splitting takes place in the upper row of screws for Type L; the parameter h_e appearing in EN 1995-1-1, (8.4), is the distance from splitting-height to the loaded side of the wooden beam.

4) Characteristic load bearing capacity for screw length $l = 100$ mm. The char. load bearing capacity can be multiplied by the screw length factor $n_s = 1.25$ for screw lengths $l = 120$ mm or by the screw length factor $n_s = 1.49$ for screw lengths $l = 140$ mm.

5) Characteristic load bearing capacity of SHERPA special screws in hardwood can be multiplied by the hardwood factor $k_{LH} = 2.3$ and for hardwood screws by $k_{LH} = 2.5$.

Product	Characteristic load bearing capacity ⁴⁾				
	R _{tor,k,SW}	R _{tor,k,GLT}	e _{grenz}	e ₂	e ₄₅
	kNmm	kNmm	mm	mm	mm
Type L 30	774	839	16.7	31.7	21
Type L 40	1 036	1 090	20	30.4	22
Type L 50	1 467	1 529	28	33.6	17
Type L 60	1 970	2 052	34.3	31.4	14
Type L 80	2 537	2 643	40.7	30.0	12
Type L 100	3 175	3 309	47.3	29.2	10
Type L 120	3 884	4 047	53.8	28.5	9

Sherpa – L

Characteristic load bearing capacities

Annex 5

of European Technical Assessment
ETA-12/0067 of 04.06.2018

Product	Dimensions H/B/L	Characteristic load bearing capacity ⁴⁾					
		R _{2,k,SW} ¹⁾	R _{2,k,GLT} ^{2) 5)}	R _{45,k,SW} ³⁾	R _{45,k,GLT} ³⁾	R _{1,k,SW}	R _{1,k,GLT} ⁵⁾
	mm	kN	kN	kN	kN	kN	kN
Type XXL 100	20/140/290	76.8	94.3	30.6	32.0	$62.3 \cdot \frac{\rho_k}{380}$	
Type XXL 120	20/140/330	99.5	122.2	37.0	38.6		
Type XXL 140	20/140/370	121.6	149.4	43.3	45.2		
Type XXL 170	20/140/410	143.3	176.0	49.8	51.9		
Type XXL 190	20/140/450	164.6	202.2	56.1	58.5		
Type XXL 220	20/140/490	185.7	228.0	62.5	65.1		
Type XXL 250	20/140/530	206.4	253.5	68.8	71.7		
Type XXL 280	20/140/570	226.9	278.7	68.8	71.7		
Type XXL 300	20/140/610	247.3	303.7	75.2	78.3		

- 1) values for solid wood or and ; splitting is not relevant for this loading direction
- 2) value for glued laminated timber; splitting is not relevant for this loading direction
- 3) splitting takes place in the middle row of screws for Type XXL; the parameter h_e appearing in EN 1995-1-1, (8.4), is the distance from splitting-height to the loaded side of the wooden beam.
- 4) Characteristic load bearing capacity for screw length $l = 160$ mm. Load bearing capacity must be reduced for screw lengths $l < 160$ mm by factor $(l-21)/139$, with l in mm. The char. load bearing capacity can be multiplied by the screw length factor $n_s = 1.13$ for screw lengths $l = 180$ mm or by the screw length factor $n_s = 1.25$ for screw lengths $l = 200$ mm.
- 5) Characteristic load bearing capacity of SHERPA special screws in hardwood can be multiplied by the hardwood factor $k_{LH} = 2.3$ and for hardwood screws by $k_{LH} = 2.5$.

Product	Characteristic load bearing capacity ⁴⁾				
	R _{tor,k,SW}	R _{tor,k,GLT}	e _{grenz}	e ₂	e ₄₅
	kNmm	kNmm	mm	mm	mm
Type XXL 100	3 448	3 610	36.7	84.6	123.2
Type XXL 120	4 460	4 668	41.7	74.7	98.5
Type XXL 140	5 700	5 967	47.5	68.8	82.1
Type XXL 170	7 079	7 410	53.7	64.9	70.4
Type XXL 190	8 660	9 065	60	60.3	61.6
Type XXL 220	10 381	10 866	66.4	57.1	54.7
Type XXL 250	12 308	12 883	72.9	54.6	49.3
Type XXL 280	13 415	14 042	79.4	59.3	49.3
Type XXL 300	15 568	16 296	86	56.9	44.8

Sherpa – XXL

Characteristic load bearing capacities

Annex 5

of European Technical Assessment
ETA-12/0067 of 04.06.2018

General

The characteristic load bearing capacities of the beam hanger connections are given for a characteristic density of 350 kg/m³. For timber or wood based material with a lower characteristic density than 350 kg/m³ the characteristic load bearing capacities shall be reduced by the factor

$$k_{\text{dens}} = \left(\frac{\rho_k}{350} \right)^{0.8} \quad \text{for } R_1 \text{ and } R_2$$

$$k_{\text{dens}} = \left(\frac{\rho_k}{350} \right)^{0.5} \quad \text{for } R_{45} \text{ and } R_{\text{tor}}$$

Where

k_{dens} Factor to consider deviating densities

ρ_k Characteristic density of timber in kg/m³

Loading against direction of insertion (with applied lift-lock)

For the case of an applied lift-lock and loading against direction of insertion, the following values need to be considered:

Sherpa	$R_{3,k}$
	kN
Type XS	3.76
Type S	5.67
Type M	8.95
Type L	17.5
Type XL	40.6
Type XXL	

Sherpa – XS, S, M, L, XL and XXL

Characteristic load bearing capacities

Annex 5

of European Technical Assessment
 ETA-12/0067 of 04.06.2018

Characteristic load bearing capacity for eccentric loading

For the case that main beam or column can not prevented from rotation in a satisfying way or are arranged rotatable according to plan, the characteristic load bearing capacity shall be calculated as follows:

For $e \leq e_{grenz}$: $R'_{2,k} = R_{2,k}$ and $R'_{3,k} = R_{3,k}$ (when a lift lock is applied)

For $e > e_{grenz}$: $R'_{2,k} = \frac{R_{2,k}}{\left[1 + \left(\frac{e - e_{grenz}}{e_2}\right)^3\right]^{\frac{1}{3}}}$ and $R'_{3,k} = \frac{R_{3,k}}{\left[1 + \left(\frac{e - e_{grenz}}{e_2}\right)^3\right]^{\frac{1}{3}}}$ (when a lift lock is applied)

$$R'_{45,k} = \frac{R_{45,k}}{\left[1 + \left(\frac{e}{e_{45}}\right)^3\right]^{\frac{1}{3}}}$$

With

e ... Distance between midplane of beam hanger and support axis of main beam (or rather column axis) in m. For e > 0,2 m additional arrangements for limiting moment interaction need to be done.

Combined loading

For combined loading, the following needs to be valid

$$\left(A_{2,d} / R_{2,d}\right)^2 + \left(A_{45,d} / R_{45,d}\right)^2 + \left(A_{1,d} / R_{1,d}\right)^2 + \left(A_{tor,d} / R_{tor,d}\right)^2 \leq 1 \text{ or}$$

with

$R_{2,d}$... Design value of load bearing capacity for loading in direction of insertion.

$R_{45,d}$... Design value of load bearing capacity for loading perpendicular to the direction of insertion.

$R_{1,d}$... Design values of load bearing capacity for loading in axis of secondary beam.

$R_{tor,d}$... Design values of load bearing capacity for loading in torsion.

$A_{2,d}$, $A_{45,d}$, $A_{1,d}$, $A_{tor,d}$... Design values of stress in direction of insertion, perpendicular to direction of insertion and in axial direction of the secondary beam and torsion.

Sherpa – XS, S, M, L, XL and XXL

Characteristic load bearing capacities

Annex 5

of European Technical Assessment
 ETA-12/0067 of 04.06.2018

